

# Steinbach

for today's lifestyle

## Installation manual

 **speedheat** Waterpower 3600

Art.Nr.: 049203 / BP-35HS-A1

 **speedheat** Waterpower 5000

Art.Nr.: 049201 / BP-50HS-A1

 **speedheat** Waterpower 8500

Art.Nr.: 049206 / BP-85HS-A1

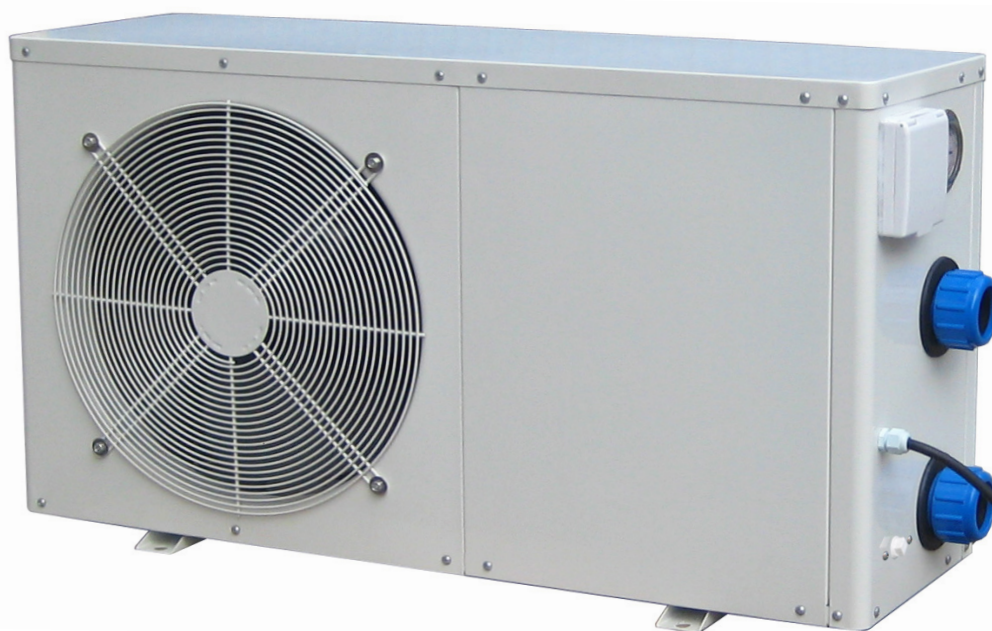



## Contents.

<b>1. General warnings and information for the addressee.....</b>	<b>5</b>
1.1. Service Processing.....	5
1.2. Warranty.....	6
1.2.1. General conditions.....	6
1.2.2. Special conditions.....	6
1.2.3. Restrictions.....	6
1.3. Symbol key.....	7
1.4. Safety regulations for heated pools.....	7
1.5. Energy savings.....	7
1.6. General information.....	7
1.7. Definitions.....	8
<b>2. Product presentation.....</b>	<b>8</b>
2.1. Product scope.....	8
2.2. Composition.....	9
<b>3. Technical specifications.....</b>	<b>10</b>
<b>4. Installation.....</b>	<b>11</b>
4.1. Inspection.....	11
4.2. Handling.....	11
4.3. Positioning.....	11
4.3.1. Support and its location.....	11
4.3.2. Necessary clearance.....	12
4.3.3. Noise wave echo.....	12
4.4. Disposal.....	12
4.4.1. General instructions.....	12
4.4.2. Heat pump decommissioning.....	12
4.4.3. Electric/electronic waste disposal.....	13
4.5. Hydraulic connections.....	13
4.5.1. Warnings.....	13
4.5.2. Installation hydraulic layout.....	13
4.6. Electrical connections.....	14
4.7. Socket installation for mains connections.....	15
4.8. Mains connection cord replacement.....	15
4.9. Commissioning, preliminary checks.....	18
4.9.1. Commissioning, precautions.....	18
4.9.2. First start-up, preliminary checks.....	18
<b>5. Operations and use.....</b>	<b>19</b>
5.1. Introduction.....	19
5.2. Control panel use.....	19
5.2.1. Turning on the heat pump.....	19
5.2.2. Standby.....	19
5.2.3. Turning off the heat pump.....	19
5.2.4. Starting the heat pump.....	20
5.2.5. Operating mode selection.....	20
5.2.6. Set temperature regulation.....	20
5.2.7. Minimum working temperature and restart temperature.....	20
5.2.8. Automatic start settings.....	21
5.2.9. Automatic standby settings.....	21
5.2.10. Manual defrost.....	22
5.2.11. Key lock.....	22
5.2.12. Sensor temperature display.....	22
5.2.13. Functional parameter settings.....	23
5.2.13.1. Pool temperature regulation range.....	25
5.2.13.2. Automatic defrost start temperature.....	25
5.2.13.3. Automatic defrost stop temperature.....	25

5.2.13.4.	Automatic defrost repetition time.....	26
5.2.13.5.	Defrost duration.....	26
5.2.13.6.	Compressor protection temperature.....	26
5.2.13.7.	Automatic restart.....	27
5.2.13.8.	Operating mode.....	27
5.2.13.9.	Maximum deviation from set temperature.....	27
5.2.13.10.	Control mode.....	28
5.3.	Manometer use.....	28
<b>6.</b>	<b>Control and safety devices.....</b>	<b>28</b>
6.1.	Control devices.....	28
6.1.1.	Ambient and pool temperature sensors.....	28
6.1.2.	Flow sensor.....	29
6.2.	Safety devices.....	29
6.2.1.	Compressor and plate heat exchanger temperature sensors.....	29
6.2.2.	High pressure sensor.....	29
6.2.3.	Low pressure sensor.....	30
6.3.	Pool, ambient and plate heat exchanger temperature sensor resistance values.....	31
6.4.	Compressor temperature sensor resistance values.....	32
<b>7.</b>	<b>Routine, scheduled and extraordinary maintenance.....</b>	<b>33</b>
7.1.	User controls.....	33
7.2.	Specialised technician controls.....	33
7.3.	Winter protection.....	33
7.4.	Spring commissioning.....	33
7.5.	Troubleshooting.....	33
<b>8.</b>	<b>Spare parts.....</b>	<b>37</b>
8.1.	Special notes on part replacement.....	42
8.1.1.	Manometer replacement.....	42
8.1.2.	Pressure sensor replacement.....	42
8.1.3.	Filter and capillary replacement.....	42
8.1.4.	Frost on radiator.....	42

## 1. General warnings and information for the addressee.

### 1.1. Service Processing

For technical information, missing parts or in the case of a complaint, please contact our customer service:

Important note: On the pump label of your heat pump is a production number shown, please provide this number in the case of a complaint.

Steinbach VertriebsgmbH, Aistingerstrasse 2, 4311 Schwertberg, AUSTRIA

Tel. Austria: (0820) 200 100 111 (0,145€ per minute from all networks)

Tel. Germany: (0180) 5 405 100 111 (0,14€ per minute from landline, mobile radio max. 0,42€ per minute)

e-mail: [service@steinbach.at](mailto:service@steinbach.at), [www.steinbach.at](http://www.steinbach.at)



Art.Nr.: 049203 / BP-35HS-A1



Art.Nr.: 049201 / BP-50HS-A1



Art.Nr.: 049206 / BP-85HS-A1

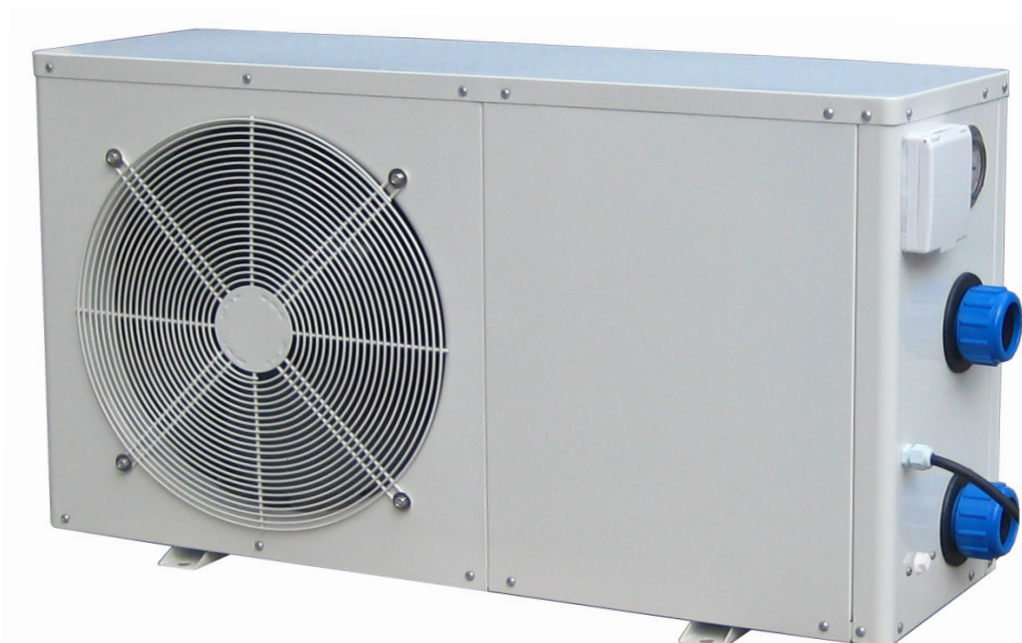

## 1.2. Warranty.

### 1.2.1. General conditions.

- i. In accordance with these provisions, the dealer guarantees that the Product under this warranty ("the Product") does not have any conformity defect upon delivery.
- ii. The Product Warranty Period is two (2) years, effective upon delivery to the purchaser.
- iii. In the event of Product conformity defects and the purchaser informs the dealer during the Warranty period, the dealer must repair or replace the Product at his/her own expense and at the site deemed most suitable, unless this is impossible or out of proportion.
- iv. Should the Product be irreparable or irreplaceable, the purchase may request a proportionate price reduction or, if the conformity defect is sufficiently important, the termination of the sales contract.
- v. Parts replaced or repaired under this warranty do not extend the length of the original Product warranty but are covered by their own warranty.
- vi. To validate this warranty, the purchaser must provide proof of Product purchase and purchase date.
- vii. Should the purchaser find conformity defects six months after delivery, the purchaser must prove the origin and existence of the defect found.
- viii. The Warranty Certificate does not restrict or compromise consumer rights provided by mandatory national regulations.

### 1.2.2. Special conditions.



- i. This warranty covers the products referred to in this manual.
- ii. This Warranty Certificate is only applicable in EU member countries.
- iii. To validate this warranty, the purchaser must strictly follow the instructions provided by the Manufacturer in the documents that accompany the Product when applicable according to Product range and model.
- iv. Should a schedule be specified for the replacement, maintenance or cleaning of some Product parts or components, the warranty is only considered valid if this schedule is correctly observed.

### 1.2.3. Restrictions.

- i. This warranty is only applicable to consumer sales where a "consumer" is the person who purchases the Product for purposes not pertinent to his/her profession.
- ii. The warranty does not cover normal wear due to Product use. As for parts, components and/or replaceable or consumable materials such as batteries, light bulbs, etc., that instructed in the documentation that accompanies the Product shall be observed.
- iii. The warranty does not cover the cases in which the Product:
  - a. was subject to incorrect treatment;
  - b. was subject to repairs, maintenance or tampering by unauthorised personnel;
  - c. was repaired and equipped with unoriginal parts.

Should the Product conformity defect be consequent to incorrect installation or commissioning procedure, this warranty shall only be applicable when this installation or commissioning procedure is included in the Product sales contract and performed by the dealer or under his/her authority.

### 1.3. Symbol key.

-  Indicates hazardous situations and warnings. The manual parts marked by this symbol must be read with the utmost care.
-  Indicates that work must not be performed on live electrical equipment. This work can begin after taking safety measures<sup>1</sup>.

### 1.4. Safety regulations for heated pools<sup>2</sup>.

-  During normal swimming activities, 26÷30 [°C] water temperature is recommended. 38 [°C] water temperature is only considered safe for adults in good health conditions. The utmost caution is recommended for use by children.

#### **Pool temperature must never exceed 40 [°C].**

-  Do not drink alcoholic beverages before, after and while swimming. Alcohol consumption may cause drowsiness, loss of consciousness and consequent drowning.

Swimming in pools with temperatures over 38 [°C] is not recommended for pregnant women. Excessively hot water could damage the foetus, especially during the first trimester, causing deformities or brain damage.

Before entering the pool, always check water temperature with a precision thermometer. Temperature regulated by the heat pump guarantees approximately  $\pm 3$  [°C] precision.

People who suffer from diabetes, heart disease, circulatory or blood pressure problems should consult a physician before entering heated pools.

If taking drugs that induce drowsiness (i.e.: tranquillizers, antihistamines or anticoagulants), avoid swimming in heated pools.

-  Prolonged immersion in hot water may cause hyperthermia<sup>3</sup>, while immersion in cold water may cause hypothermia<sup>4</sup>, with symptoms such as: Dizziness, fainting, drowsiness, lethargy<sup>5</sup>. Consequences of hyperthermia and hypothermia may be: unawareness of imminent danger, lack of heat or cold perception, failure to recognise the need to exit the pool, physical inability to exit the pool, damages to foetus for pregnant women, unconsciousness with consequent drowning risks.

### 1.5. Energy savings.

The heat pump slowly heats pool water. For weekend use, keeping pool temperature at the desired value even when not in use is recommended. If temperature is allowed to drastically reduce, several days may be required to restore the desired temperature. In the event of prolonged pool disuse (more than one week), turning off the heat pump or reducing the set temperature by several degrees is recommended to save energy.

The difference between the ambient temperature and water temperature should never be over 15 [°C]. For this reason, do not use the heat pump when the ambient temperature is under 15 [°C]. Please see [Paragraph 5.2.7](#).

For improved energy savings, using the automatic start and stop functions is recommended. Please see [Paragraph 5.2.8](#) and [Paragraph 5.2.9](#).

Once the ideal water temperature is set, use the key lock function to prevent changes to the set temperature and/or prevent other adjustments. Please see [Paragraph 5.2.11](#).

Protect the pool from wind.

When the pool is not in use, cover it with a tarp to limit heat dispersion.

### 1.6. General information.

-  SERIES BP heat pumps are devices accessible to the public and were designed to heat and cool water intended for home pools.

<sup>1</sup> This symbol may be found on the labels on SERIES BP heat pumps.

<sup>2</sup> Guidelines for safe recreational water environments - VOLUME 2 - SWIMMING POOLS AND SIMILAR ENVIRONMENTS - WORLD HEALTH ORGANIZATION 2006.

<sup>3</sup> Increase in body temperature over physiological limits, maximum limit 37 [°C].

<sup>4</sup> Decrease in body temperature over physiological limits, minimum limit 35 [°C].

<sup>5</sup> State of inactivity or lack of reactivity that nears unconsciousness.

⚠ SERIES BP heat pumps must not be used with other heating systems such as electric heaters.

⚠ This manual provides instructions for the installation and use of SERIES BP heat pumps. Carefully read this manual before installation. Failure to observe the manual instructions may cause personal or property damages or damage the heat pump.

⚠ Failure to observe the instructions in this manual immediately null and voids the warranty.

⚠ Steinbach VertriebsgmbH is not liable for any damages due to improper heat pump use. The manual must be kept integral and in good conditions. It must accompany the heat pump until it is decommissioned.

In the event of malfunctions, consult the instruction manual and, if necessary, contact specialised technicians.

⚠ Installation and maintenance must be performed by qualified technicians unless otherwise indicated in the manual.

⚠ Initial system commissioning must only be performed by specialised technicians.

⚠ Working on the heat pump when connected to the electrical mains is strictly prohibited. Only begin work after taking the safety measures.

The heat pump is not suited for people (even children) who suffer from physical, sensorial or mental handicaps or people who do not have sufficient experience or training unless instructed on heat pump use and assisted by a person in charge of their safety. Supervise children to ensure they do not play with the device.

Steinbach VertriebsgmbH continually strives to improve all types and models. We trust the user will understand the technical modifications Steinbach VertriebsgmbH reserves the right to make on the shape and fittings on SERIES BP heat pumps.

## 1.7. Definitions<sup>6</sup>.

**Power cord:** flexible cord, for power supply, attached to the device.

**Tool:** Screwdriver, coin or any other object that can be used to move a screw or similar fastening device.

**Protection device:** Device whose operations prevent hazardous situations in abnormal operating conditions.

**Contact switch disconnection:** Disconnection of both power conductors with a single contact opening action.

**Heat pump:** device that absorbs heat at a given temperature and releases it at a higher temperature.

**Heat exchanger:** device specifically designed to transfer heat between two physically separate fluids.

**Compressor:** device specifically designed to increase fluid pressure.

**Evaporator:** heat exchanger where coolant is vaporised by heat absorption.

**Pressure limiter device:** mechanism that automatically responds to a set pressure, interrupting the operations of the element that controls pressure.

**Device accessible to the public:** device intended to be installed in homes or commercial buildings.

**Installation manual:** document intended for specialised technicians that illustrates how to commission and maintain the heat pump.

**User manual:** document intended for the end user that illustrates how to use the heat pump.

**Necessary clearance:** minimum heat pump installation area.

## 2. Product presentation.

### 2.1. Product scope.

SERIES BP heat pumps were designed to heat and cool water intended for home pools.

<sup>6</sup> Definitions in accordance with regulation CEI EN 60335.



## 2.2. Composition.

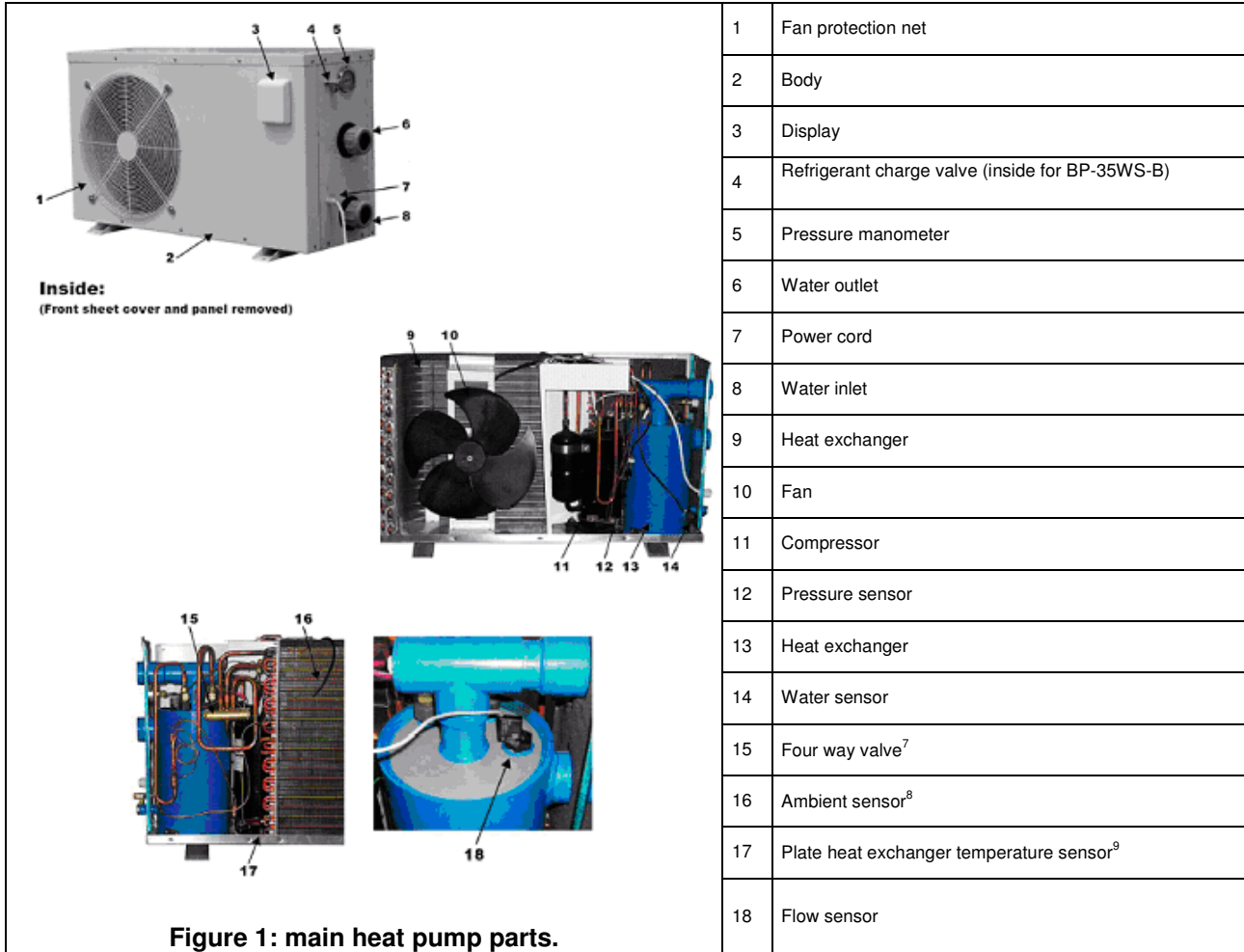

<sup>7</sup> Not included in model BP-xxWS-B (xx=35, 50).

<sup>8</sup> Not included in model BP-xxWS-B (xx=35, 50).

<sup>9</sup> Not included in model BP-xxWS-B (xx=35, 50).

## 3. Technical specifications.

	Unit of measure	Model					
		BP-35HS-A1	BP-50WS-B	BP-50HS-A1	BP-8HS-A1	BP-100HS-A	BP-160HS-A
Thermal power (heating) <sup>10</sup> A26/W27	[kW]	3.9	5.0	5.1	8.3	10.5	17.0
Refrigerant power (cooling) A32/W27	[kW]	2.7		3.4	5.8	8.5	
Absorbed power <sup>12</sup>	[kW]	0.75	1.0	1.0	1.7	2.1	3.5
Absorbed current <sup>13</sup>	[A]	3.6	5.5	4.4	7.5	9.8	16
Power voltage <sup>14</sup>	[V] [Hz]						
COP (Coefficient Of Performance) A15/W27	[W/W]	5.2	5.0	5.3	5.2	5.0	5.0
ERR (Energy Efficient Ratio) A32/W27	[W/W]	3.5		3.5	3.5	4.0	4.0
Refrigerant	-	R410A					
Refrigerant gas quantity	[kg]	0.75	0.85		1.60		2.85
Protection grade at water input	-	IPX4					
Number of compressors	-	1					
Compressor type	-	Rotary					
Heat exchanger	-	Titanium					
Minimum water flow	[m <sup>3</sup> /h]	3.5	4	6	4.0	6.5	
Hydraulic connections	[mm]	50					
Number of fans	-	1					
Absorbed power by fan	[W]	70		85	100	220	
Fan RPM	[RPM]	830		900	850	800	
Fan air flow direction		Horizontal					
Fan air flow	[m <sup>3</sup> /h]	1200	1600	2000		3400	
Noise	[dB(A)]	50	51	53	54	60	
Dimensions (L/D/H)	[mm]	760x270x470	955x305x565		1005x305x610	1120x430x790	
Net/gross weight	[kg]	34/38	51/54	54/57	63/67	114/124	

<sup>10</sup> Variable according to ambient conditions.

<sup>11</sup> Operating mode not included.

<sup>12</sup> Variable according to ambient conditions.

<sup>13</sup> Variable according to ambient conditions.

<sup>14</sup> Single phase alternating current.

<sup>15</sup> Operating mode not included.

## 4. Installation.

 The heat pump must be installed and commissioned by specialised technicians and in keeping with current national system regulations.

 Installation must be conducted evaluating all the specific site factors: vicinity and height of walls, public accessibility, etc.

### 4.1. Inspection.

 Upon receiving the heat pump, check packaging integrity. The machine should come with complete **manuals**, for the user and for installation.

### 4.2. Handling.

 The unit is equipped with suitable protections to protect the heat pump for any damages during handling. Avoid exerting pressure on the sides of the packaging.

Once the heat pump is unpacked, avoid exerting pressure on the body, plate heat exchanger and fan protection net. See [Figure 1](#).

### 4.3. Positioning.

 The heat pump must be positioned by specialised technicians and in keeping with current national system regulations.

The heat pump must be carefully positioned considering the following aspects:

- Dimensions and origin of hydraulic tubes.
- Location of the power supply.
- Support and its location.
- Necessary clearance.
- Noise wave and vibration echo.
- Condensation discharge.

#### 4.3.1. Support and its location.

 **The heat pump must be installed outdoors. It cannot be installed indoors and must be at least 3.5 [m] from the pool surface (zone 2<sup>16</sup>).**

 **During normal operations, the heat pump plate heat exchanger produces condensation. The amount of condensation produced varies according to ambient conditions. The higher the air humidity, the higher the amount of condensation produced. The heat pump comes with a condensation drain. Make sure there are no obstacles to condensation draining.**

The heat pump must be positioned to avoid damages attributable to any water or condensation leaks. If necessary, install suitable discharge outlets or collection containers.

 The heat pump must be installed on a solid and level support (cement slab or prefabricated platform). Avoid positioning the heat pump on instable ground. In this case, installing a suitably dimensioned support slab or platform is recommended. The support surface must be slightly tilted to promote correct rain water and condensation draining from the device base.

Support surface inclination must be a maximum of 2%.

 Make sure the pump is not subject to rain water flows from nearby building roofs. Protruding roofs without gutters could pour significant amounts of water and/or debris on the heat pump which could damage it. If necessary, install gutters or discharge outlets to protect the heat pump.

 **If the heat pump is installed under the pool level, any water leaks could cause significant water leaks or floods. Shott International SRL is not liable for any of said leaks, floods or consequent damages.**

 Make sure the heat pump is not within the range of action of any irrigation systems. If necessary, install suitable protections.

<sup>16</sup> See CEI 64-8/7 for pool zone classifications.

### 4.3.2. Necessary clearance.

Minimum clearance required for heat pump installation is illustrated in the following figure.

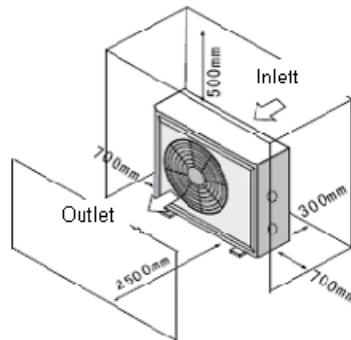

**Figure 2: Clearance required for correct installation.**

Clearance guarantees accessibility during SERIES BP heat pump maintenance and operations.



Avoid hot air from circulating between machine distribution and suction. See [Figure 2](#). For this purpose, avoid all situations in which there could be an obstacle to the free flow of air produced by the fan. Specifically, pay careful attention to the direction of strong winds in the heat pump installation area. Strictly avoid installing the heat pump where the direction of strong wind is contrary to heat pump flow.

### 4.3.3. Noise wave echo.

SERIES BP heat pumps were designed with special attention to noise and vibrations. Retail or accessory shock absorbers can be used to diminish vibrations and noise.



**Figure 3: Shock absorber supports.**

To diminish noise wave echoes, avoid positioning the pump in the immediate vicinity of vertical walls.

## 4.4. Disposal.

### 4.4.1. General instructions.



Collecting recyclable material, both those used for packaging (cardboard, nylon, etc.) and those replaced during routine and extraordinary maintenance is recommended.

Suitable collection of waste material for recycling, processing and environmentally compatible disposal contributes in avoiding possible negative effects on the environment and health and promote the reuse and/or recycling of device materials.

Illicit product disposal by the user may be punishable by current national laws.



### 2. Heat pump decommissioning.

When the unit reaches the end of its working life and must be removed and/or replaced, follow the instructions below:

- Refrigerant gas must be collected by specialised technicians and sent to collection centres.
- Compressor lubricant oil must be collected by specialised technicians and sent to collection centres.

- The body and various parts, if unusable, should be dismantled and divided according to their material type (for example, copper, aluminium, plastic, etc.) and must be sent to collection centres.

#### 4.4.3. Electric/electronic waste disposal.



In keeping “Implementation of Directives 2002/95/CE, 2002/96/CE and 2003/108/CE” on the reduction of the use of hazardous substances in electric and electronic material as well as waste disposal. The barred bin symbol on the equipment or packaging indicates that the product must be separated from other waste at the end of its working life. Therefore, the user must take equipment to electronic and electro-technical waste collection centres at the end of its working life or return it to the dealer when purchasing similar new equipment, on a one to one basis. Suitable collection of decommissioned equipment for recycling, processing and environmentally compatible disposal contributes in avoiding possible negative effects on the environment and health and promote the reuse and/or recycling of device materials. Illicit product disposal by the user may be punishable by current national laws.

#### 4.5. Hydraulic connections.

##### 4.5.1. Warnings.



The heat pump hydraulic connections must be performed by specialised technicians and in keeping with current national system regulations.



During hydraulic connections, avoid using free flames near or within the heat pump.



The following retail components are recommended for hydraulic connections:

- Cut-off valves upstream and downstream from the heat pump to facilitate maintenance and/or heat pump bypass from the pool hydraulic system.
- Hydraulic circuit charge and drain valve for the heat pump.
- Hydraulic circuit bypass valve, see [Figure 6](#).
- Mechanical filter upstream from the heat pump, usually a sand filter.
- Non-return valve, installed between the pool and the heat pump output fitting, to prevent water reflux.



Tubes that have the same diameter of the heat pump inlet and outlet are recommended for upstream and downstream heat pump connections.



During periods of heat pump disuse, for example, during the winter, drain water from the heat pump circuit and heat pump.



Chemical dosing devices, when applicable, must be installed downstream from the heat pump and non-return valve. This prevent chemically saturated water reflux which could damage the heat pump.

##### 4.5.2. Installation hydraulic layout.

The hydraulic circuit where the heat pump is installed must be created observing the following general layout.

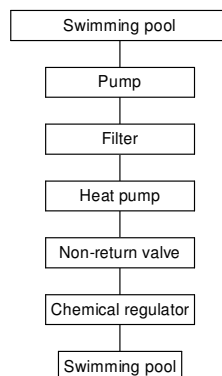

Figure 4: General hydraulic circuit layout.

The pump must be hydraulically connected with PVC tubes with 50 [mm] external diameters. Tubes must be inserted in the fittings for about 1÷2 [cm] and secured with the supplied fast connections.



**Figure 5: Hydraulic connections**

The hydraulic circuit is usually created as illustrated in the following figure.

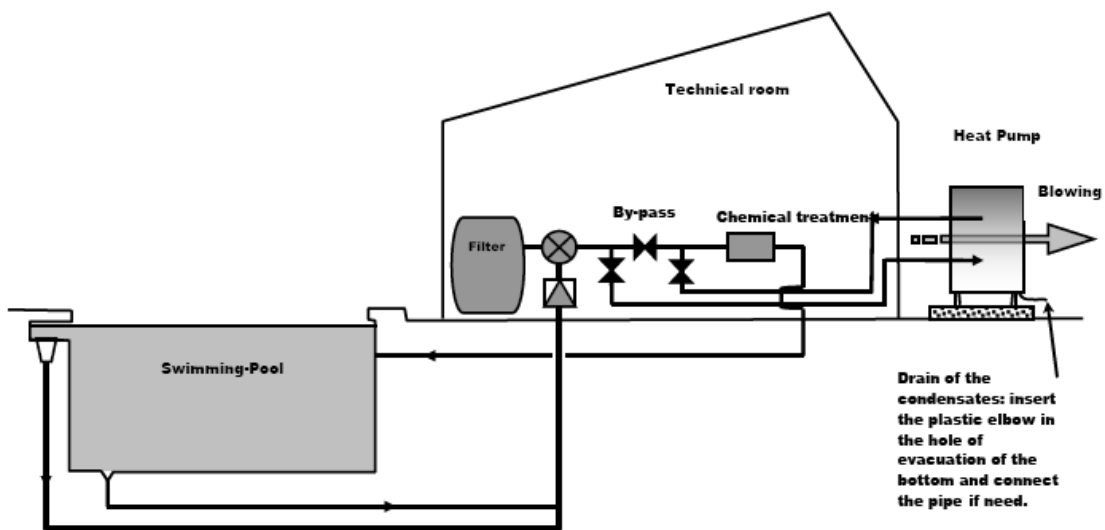
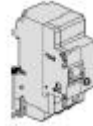

**Figure 6: Typical hydraulic circuit part layout.**

**Minimum heat pump water input flow must not be under the value required for the model in question. See [Paragraph 2](#).** For system layouts such as that in [Figure 6](#), water flow can be regulated using the bypass valve.

#### 4.6. Electrical connections.

- ⚠ **The heat pump electrical connections must be performed by specialised technicians and in keeping with current national system regulations.**
- ⚠ **Working on live electrical equipment is prohibited. Before starting work, make sure the heat pump is disconnected from the electrical mains.**  
**Modifying electrical connections inside the heat pump without Steinbach VertriebsgmbH authorisation is strictly prohibited.**
- ⚠ **Electrical connections must be performed as illustrated in the wiring diagram in [Figure 10](#).** Power voltage must not vary more than 10 % from the nominal value. It must be within the 207÷253 [V] interval. If power voltage is subject to frequent variations, contact specialised technicians for suitable protection devices.  
Install a protection device, circuit breaker with delayed type 16 [A] fuse, upstream from the heat pump. This protection device must only service the heat pump. Furthermore, install a contact switch protection device, circuit breaker, that has nominal operating differential current not over 30 [mA].



**Figure 7: Protection device and/or contact switch.**

- ⚠ The electrical mains connected to the heat pump must be grounded. If a socket is installed for electrical mains connections, the latter must have a protection grade no lower than IPX4 and must have a grounding terminal. The same applies for the mains which must be grounded.

#### 4.7. Socket installation for mains connections.

- ⚠ Use a socket with nominal current no lower than 16 [A] equipped with a grounding terminal with protection grade no lower than IPX4.

Proceed as follows to install the mains connection socket:

- ⚠
  - **Make sure the heat pump is disconnected from the mains.**
  - Open the socket and connect the heat pump power wires to the terminals. Make sure electrical connections observe that illustrated in the following figure, [Figure 8](#). Terminal names:
    - L. phase conductor;
    - N, neutral conductor;
    - , grounding conductor.
  - Close the socket.

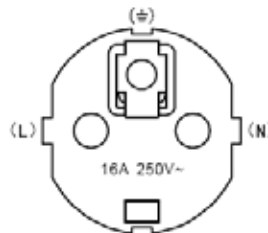

**Figure 8: Socket connection illustration.**

#### 4.8. Mains connection cord replacement.

- ⚠ Use a three-polar cord no lighter than an ordinary rubber sheathed flexible cord<sup>17</sup>, each conductor section must not be lower than 1.5 [mm<sup>2</sup>].

Proceed as follows to replace the mains connection cord:

- ⚠
  - **Make sure the heat pump is disconnected from the mains.**
  - Remove the upper heat pump panel by unscrewing the fastening screws.
  - Remove the control board protection panel by unscrewing the fastening screws.
  - Disconnect the mains connection wire from the terminals, see [Figure 9](#) and [Figure 9](#).
  - Install the new mains connection cord using the supplied or similar raceway.
  - Connect the connection cord to the electrical mains observing terminal names:
    - L. phase conductor;
    - N, neutral conductor;
    - , grounding conductor.
  - Reassemble the control board protection panel and upper panel.



**Figure 9: Mains connection terminals.**

<sup>17</sup> 60245 IEC 57 designation.

## Model BP-xxHS-A (xx= 35, 50, 85, 100).

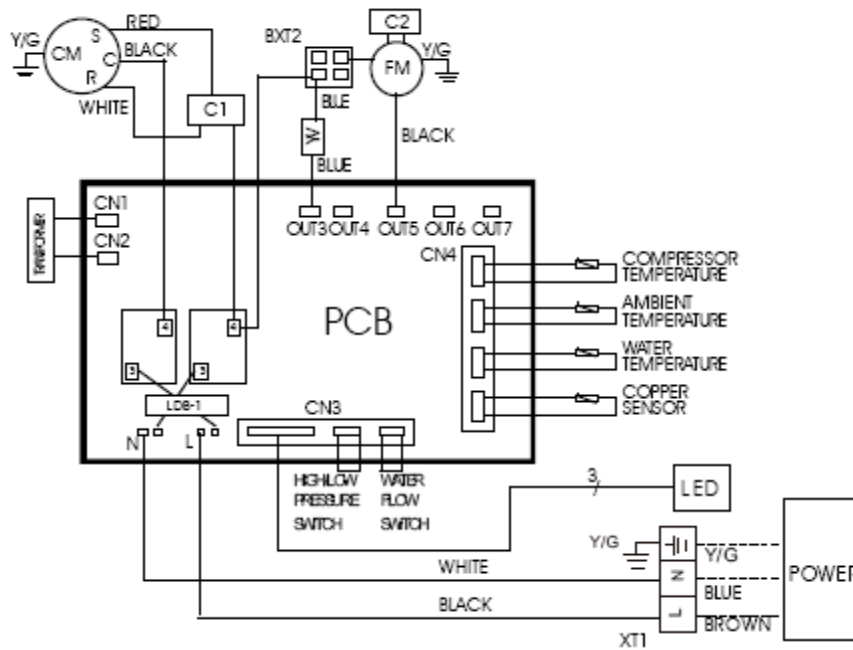

## Model BP-xxWS-B (xx=35, 50).

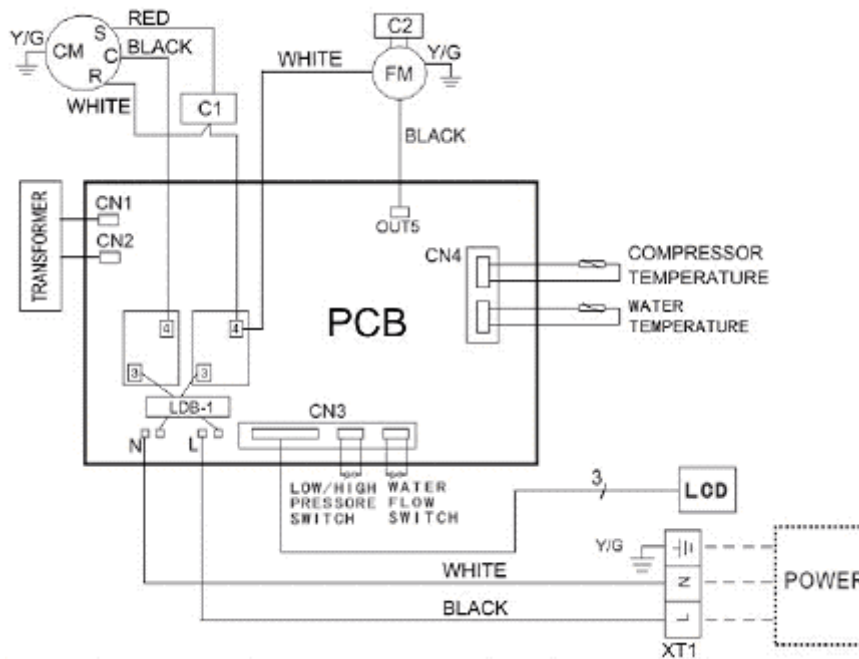



## Model BP-160HS-A.

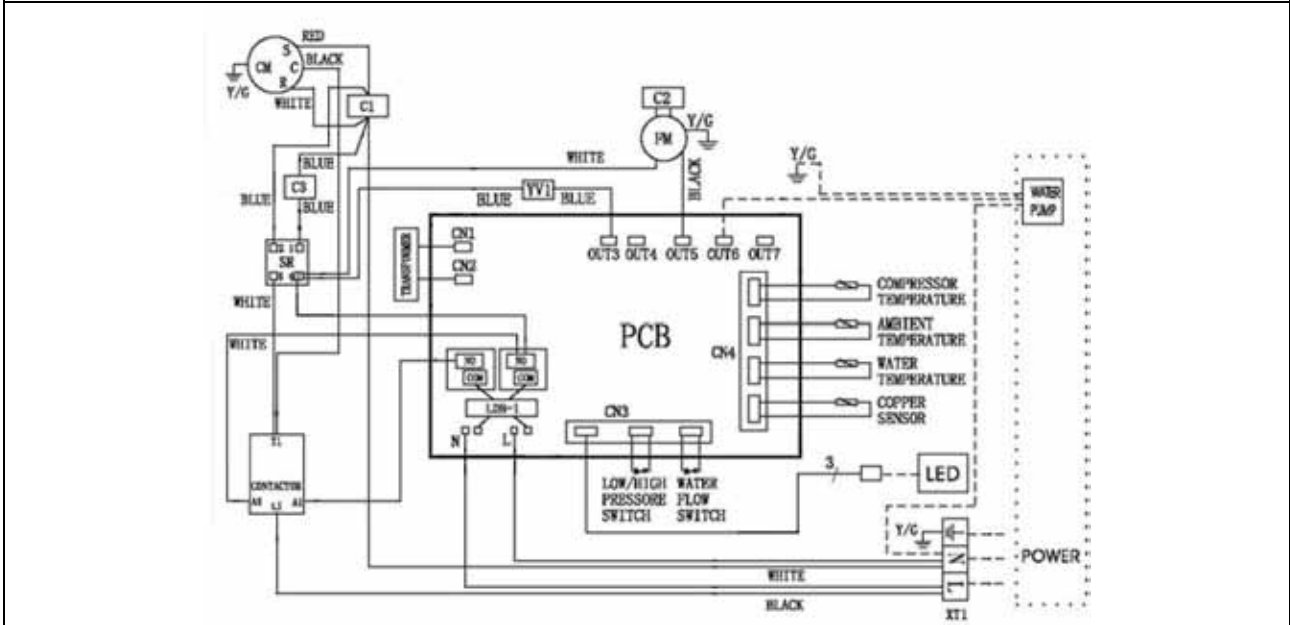

Figure 10: Wiring diagram.

YV	Four way valve
FM	Fan motor
CM	Compressor
PCB	Control board
LDB-1	Dispersion sensor
XT1	Electrical mains connection terminals
XT2	Hub
C1	Compressor capacitor
C2	Fan capacitor

Table 1: Control board part legend.

## 4.9. Commissioning, preliminary checks.

### 4.9.1. Commissioning, precautions.



Before starting the pump, make sure there is water in the pool, that the skimmer and suction fittings, when installed, are submerged, that the cut-off valves do not prevent water flow from the pool to the heat pump and vice versa and that the circulation pump is on.

### 4.9.2. First start-up, preliminary checks.



At first heat pump start-up, make sure that:

- the electrical mains were connected in keeping with current national system regulations, see [Paragraph 4.6](#).
- there are no refrigerant fluid leaks checking the pressure on the manometer, see [Paragraph 5.3](#), using leak detection devices.
- Make sure hydraulic connections were correctly performed, see [Paragraph 4.5](#).
- Make sure all body panels are in place and locked with screws.
- Make sure there are no impediments to free water flow from the pool to the heat pump and vice versa.

## 5. Operations and use.

### 5.1. Introduction.



Please read the paragraph on energy savings, see [Paragraph 1.5](#).

SERIES BP heat pumps are equipped with control boards which, thanks to a simple but functional interface, allow heat pump programming to guarantee efficient service.

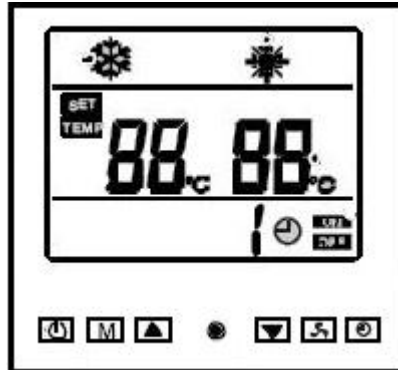

Figure 11: Heat pump panel.

	Heat pump on/off button.
	Operating mode selection button (heating/cooling <sup>18</sup> ) or operating parameter programming access.
	Up button.
	Down button.
	Multi-function button.
	Timer or temperature control on/off button.
	Heat pump operating mode indication: cooling. <sup>19</sup>
	Heat pump operating mode indication: heating.

Table 2: control panel display symbol key.

### 5.2. Control panel use.

The control panel displays all information required for the user, data and/or error messages. Please see [Paragraph 7.5](#).

#### 5.2.1. Turning on the heat pump.

Use the protection device and/or contact switch to turn on the heat pump. Please see [Paragraph 4.6](#).

#### 5.2.2. Standby.

Water temperature is displayed when the heat pump is turned on. Please see [Figure 12](#). The heat pump is in standby conditions. It does not heat or cool pool water.

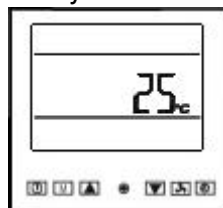

Figure 12: Heat pump display in standby conditions.

#### 5.2.3. Turning off the heat pump.



Use the protection device and/or contact switch to turn off the heat pump. Please see [Paragraph 4.6](#).

Make sure the heat pump is in standby before turning it off.

<sup>18</sup> The BP-xxWS-B (xx=35, 50) model has only one operating mode: heating.

<sup>19</sup> Operating mode not included in model BP-xxWS-B (xx=35, 50).

## 5.2.4. Starting the heat pump.

To start the heat pump, press . The heat pump starts within 3 minutes. The last selected operating mode (heating or cooling<sup>20</sup>), see [Figure 13](#), [Figure 14](#) and [Paragraph 5.2.13.8](#), the last temperature set and the current pool water temperature (heating or cooling) is immediately displayed.

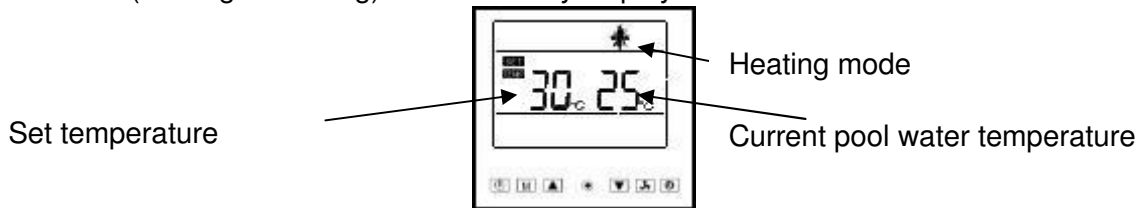

Figure 13: Heat pump display when turned on, heating mode.

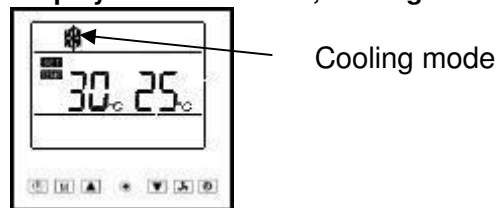

Figure 14: Heat pump display when turned on, cooling mode.

## 5.2.5. Operating mode selection<sup>21</sup>.

Start the heat pump, see [Paragraph 5.2.4](#), press to select the operating mode:

- Heating, is displayed, see [Figure 13](#).
- Cooling, is displayed, see [Figure 14](#).



Whenever the operating mode changes, the set temperature is switched to the following default values:

- Heating mode, 40 [°C].
- Cooling mode, 30 [°C].

Thus, the set temperature must be regulated, see [Paragraph 5.2.6](#), whenever the operating mode changes.

## 5.2.6. Set temperature regulation.



Before regulating the set temperature, carefully read the instructions in [Paragraph 1.4](#).

Set temperature can be regulated by pressing to increase it and to decrease it. Set temperature can be selected in the interval 5÷45 [°C].

Parameter programming, upon heat pump assembly, guarantees that the difference between pool water temperature and set temperature is never over 3 [°C] as illustrated by the following examples:

- Heating mode, set temperature 30 [°C], pool water temperature is never under 27 [°C].
- Cooling mode, set temperature 15 [°C], pool water temperature is never over 18 [°C].

## 5.2.7. Minimum working temperature and restart temperature<sup>22</sup>.

Once the pump is started, see [Paragraph 5.2.4](#). if the ambient temperature is lower than the minimum working temperature, the heat pump stops, displaying error message “EE C”, and only restarts if the ambient temperature exceeds the restart temperature. When the pump is constructed, the minimum working temperature and

<sup>20</sup> Operating mode not included in model BP-xxWS-B (xx=35, 50).

<sup>21</sup> Not included in model BP-xxWS-B (xx=35, 50).

<sup>22</sup> Not included in model BP-xxWS-B (xx=35, 50).

restart temperature are a  $-15$  [°C] and  $-13$  [°C] respectively, minimum admissible values.



The minimum working temperature must be at least  $2$  [°C] lower than the restart temperature.

Proceed as follows to set minimum working temperature:

- When the pump is in standby, see [Paragraph 5.2.2](#), press and hold down for 3 seconds.

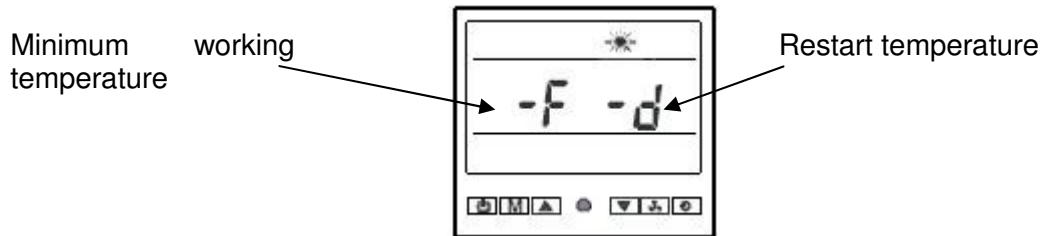
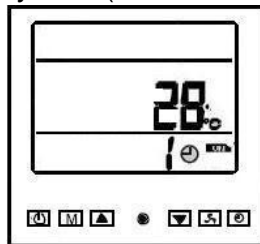

**Figure 15: Minimum working temperature and restart temperature.**

- Regulate minimum working temperature with keys (increase), (decrease). Minimum working temperature cannot be under  $-15$  [°C] (-F), the regulation interval for minimum working temperature is  $-15\div 97$  [°C].
- Press , to regulate the restart temperature.
- Regulate restart temperature with keys (increase), (decrease). Minimum restart temperature cannot be under  $-13$  [°C] (-d), the regulation interval for restart temperature is  $-13\div 99$  [°C].

### 5.2.8. Automatic start settings.

When the pump is in standby, see [Paragraph 5.2.2](#), press to turn on the automatic start mode. Press (increase), (decrease) to select when the heat pump should automatically start ( $1\div 24$  hours).



**Figure 16: Automatic start settings.**



Automatic start can only be set when the pump is in standby, see [Paragraph 5.2.4](#).

### 5.2.9. Automatic standby settings.

When the pump is running, see [Paragraph 5.2.4](#), press to turn on the automatic standby mode. Press (increase), (decrease) to select when the heat pump should automatically return to standby mode ( $1\div 24$  hours), see [Paragraph 5.2.2](#).

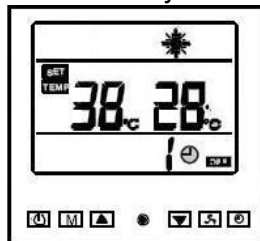

**Figure 17: Automatic standby settings.**

Automatic standby can only be set when the pump is running, see [Paragraph 5.2.4](#).

## 5.2.10. Manual defrost<sup>23</sup>.

Frost may form on the plate heat exchanger during normal operations in heating mode, see [Figure 1](#). Frost on the plate heat exchanger reduces heat pump performance. Frost is formed during heating mode because the heat pump cools surrounding ambient air to heat water. SERIES BP pumps are equipped with a temperature sensor that detects frost on the plate heat exchanger and starts automatic defrost. However, if this is insufficient, manual defrost can be started.



Manual defrost can only be started when the heat pump is running in heating mode.

When the pump is running, see [Paragraph 5.2.4](#), press  and hold down for 5 seconds to turn on manual defrost. Manual defrost lasts several minutes. At the end of the manual defrost cycle, the heat pump automatically starts.

When defrosting, refrigerant fluid pressure is increased to make refrigerant fluid hotter so that it heats the plate heat exchanger during circulation to defrost.



When defrosting, refrigerant fluid pressure significantly increases. For further information, see [Paragraph 5.3](#).



The heating mode icon blinks during defrost. See [Figure 18](#).

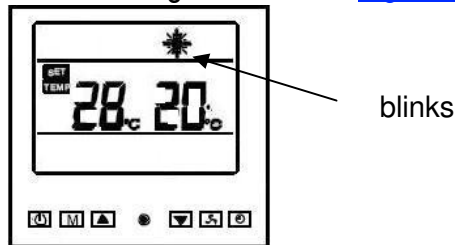



Figure 18: Manual defrost.

## 5.2.11. Key lock.

Keys can be locked to prevent accidental regulations.

To lock keys, press and simultaneously hold down keys  and  for 5 seconds.

Symbol  will appear on the display. See [Figure 19](#) and [Figure 20](#).

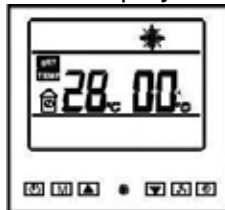

Figure 19: Key lock, heating mode.

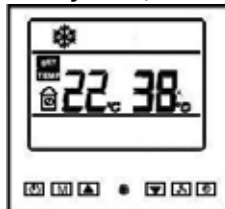

Figure 20: Key lock, cooling mode.





## 5.2.12. Sensor temperature display.

SERIES BP heat pumps are equipped with 4 temperature sensors that continuously read pool water, ambient<sup>24</sup>, compressor and plate heat exchanger temperatures<sup>25</sup>.

<sup>23</sup> Operating mode not included in model BP-xxWS-B (xx=35, 50).

<sup>24</sup> Not included in model BP-xxWS-B (xx=35, 50) where the sensor is not installed.

<sup>25</sup> Not included in model BP-xxWS-B (xx=35, 50) where the sensor is not installed.

The temperature read by each sensor can be displayed by pressing  (for model BP-xxWS-B (xx=35, 50), press ) and hold down for 3 seconds with the pump is running, see [Paragraph 5.2.4](#). To display temperatures read by the various sensors, press  (for model BP-xxWS-B (xx=35, 50), press ). The temperature read by the sensor is displayed for 10 seconds, if no other key is pressed, or press  to return usual information to the display, see [Figure 13](#) and [Figure 14](#).

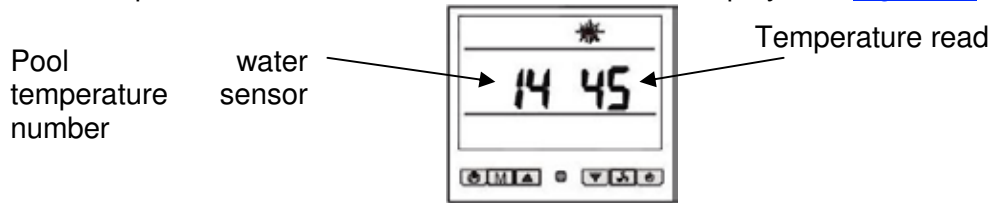

Figure 21: Pool water temperature sensor.

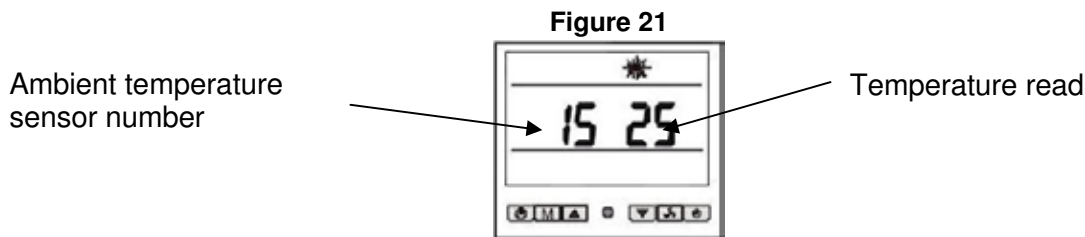

Figure 22: Ambient temperature sensor<sup>26</sup>.

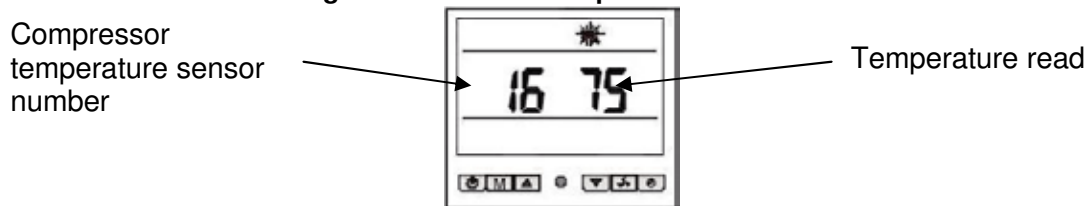

Figure 23: Compressor temperature sensor.

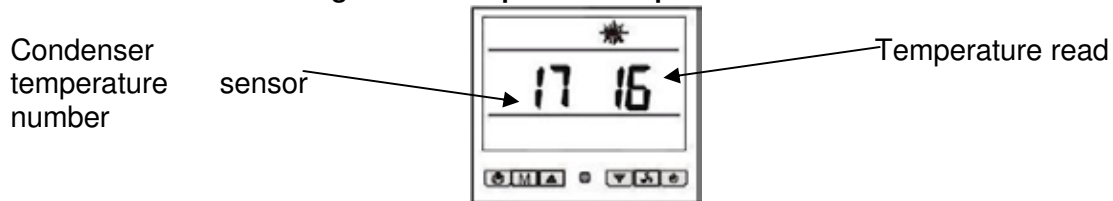

Figure 24: Condenser temperature sensor.

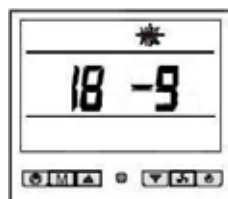





Figure 25: Sensor not used<sup>27</sup>.

### 5.2.13. Functional parameter settings.

**This paragraph is exclusively reserved to specialised technicians in charge of heat pump installation. Changing functional parameters, if incorrectly performed, can compromise correct heat pump operations.**

When the pump is in standby, see [Paragraph 5.2.2](#), press  and hold down for 3 seconds to access programming parameters. Press  to select the required parameter and change the value using keys  (increase),  (decrease). If no

<sup>26</sup> For model BP-xxWS-B (xx=35, 50), parameter 15 indicates the compressor temperature sensor.

<sup>27</sup> Not used for SERIES BP heat pump control.

key is pressed within 10 seconds or if  is pressed, usual standby mode information is displayed, see [Paragraph 5.2.2](#).

Each parameter is marked by an identification number. The following table lists for each parameter:

- Identification number
- Description.
- Admissible value range.
- Default settings (set at heat pump assembly).

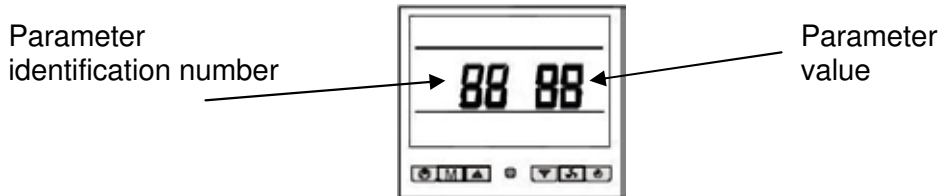

**Figure 26: Parameter programming.**

 Some of the parameters listed in the following table may not be used for SERIES BP heat pump control.

<b>BP-xxHS-A (xx=35,50, 85, 100, 160) models.</b>				
Identification number	Description.	Admissible value range.	Editable	Default value
0	Pool temperature regulation range	0÷1	No	0
1	Automatic defrost start temperature	-20÷10 [°C]	Yes	-7 [°C]
2	Automatic defrost stop temperature	5÷45 [°C]	Yes	12 [°C]
3	Automatic defrost repetition time	30÷150 [min]	Yes	F0 (150 [min])
4	Defrost duration	1÷15 [min]	No	3 [min]
5	Compressor protection temperature	70÷110 [°C]	Yes	95 [°C]
6	Parameter not used	0÷60 [°C]	No	7 [°C]
7	Parameter not used	0/1	No	1
8	Automatic restart	0/1	No	1
9	Operating mode	0/1/2/3	<b>Not recommended</b>	1
10	Maximum deviation from set temperature	1÷10 [°C]	Yes	3 [°C]
11	Control mode	0/1	No	0
<b>BP-xxWS-B (xx=35, 50) model.</b>				
Identification number	Description.	Admissible value range.	Editable	Default value
0, see previous table parameter 10	Maximum deviation from set temperature	1÷10 [°C]	Yes	3 [°C]
1, see previous table parameter 5	Compressor protection temperature	70÷110 [°C]	Yes	95 [°C]
2, see previous table parameter 8	Automatic restart	0/1	No	1

**Table 3: Parameter description table.**



## 5.2.13.1. Pool temperature regulation range<sup>28</sup>.

Parameter 0 sets the water temperature regulation range. One of the following two ranges can be selected:

0. 5÷45 [°C];
1. 5÷60 [°C].

With default settings, pool temperature can be regulated in the range 5÷45 [°C]. For further information, see [Paragraph 1.4](#).



**Do not change this parameter.**

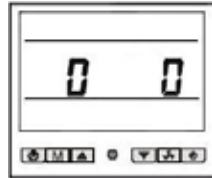

Figure 27: Parameter 0 settings, default settings.

## 5.2.13.2. Automatic defrost start temperature<sup>29</sup>.

Parameter 1 sets the ambient temperature at which automatic defrost starts. The value can be selected from range -20÷10 [°C].

Default settings are -7 [°C]. This value can be adjusted according to ambient conditions. We recommend:

- -10 [°C] if the machine is installed in a very cold country (i.e.: Northern Europe);
- -5 [°C] if the machine is installed in a very hot country (i.e.: Southern Europe).

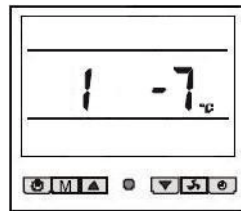

Figure 28: Parameter 1 settings, default settings.

## 5.2.13.3. Automatic defrost stop temperature<sup>30</sup>.

Parameter 2 sets the plate heat exchanger temperature at which automatic defrost starts. The value can be selected from range 5÷45 [°C].

Default settings are 12 [°C]. This value can be adjusted according to ambient conditions. We recommend:

- 15 [°C] if the machine is installed in a very cold country (i.e.: Northern Europe);
- 10 [°C] if the machine is installed in a very hot country (i.e.: Southern Europe).

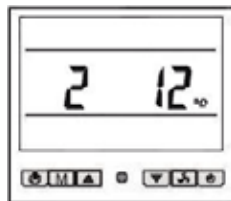

Figure 29: Parameter 2 settings, default settings.

<sup>28</sup> Not included in model BP-xxWS-B (xx=35, 50).

<sup>29</sup> The defrost process only starts when both conditions set in parameters 1 and 3 are met. **Not included in model BP-xxWS-B (xx=35, 50).**

<sup>30</sup> The automatic defrost process only stops when one of the conditions set in parameters 2 or 4 are met. **Not included in model BP-xxWS-B (xx=35, 50).**

### 5.2.13.4. Automatic defrost repetition time<sup>31</sup>.

Parameter 3 is used to select when the automatic defrost process is started. The value can be selected in range 10÷150 minutes.

Default settings are 150 minutes (F0). The minimum increase or decrease of this parameter can be 10 minutes. This parameter can be changed according to ambient conditions. Reducing the automatic defrost process in very cold countries (i.e.: Northern Europe) is recommended, 120 minutes (C0).

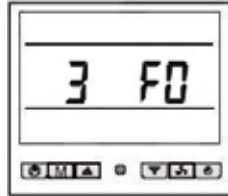

Figure 30: Parameter 3 settings, default settings.

### 5.2.13.5. Defrost duration<sup>32</sup>.

Parameter 4 is used to select automatic and manual defrost duration. The value can be selected from range 1÷15 minutes. Default settings are 3 minutes.



**Do not change this parameter.**

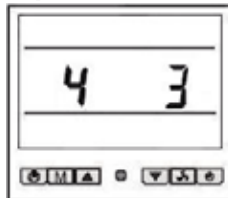

Figure 31: Parameter 4 settings, default settings.

### 5.2.13.6. Compressor protection temperature.

Parameter 5 (Parameter 1 for model BP-xxWS-B (xx=35, 50)) is used to select the maximum compressor temperature. This temperature is continuously monitored by a specific sensor, see [Paragraph 5.2.12](#). The value can be selected from the range 70÷110 [°C]. Default settings are 95 [°C].



**Do not change this parameter.**

BP-xxHS-A (xx=50, 85, 100, 160) models.
BP-xxWS-B (xx=35, 50) model.

Figure 32: Parameter 5 settings (Parameter 1 for model BP-xxWS-B (xx=35, 50)), default settings.

<sup>31</sup> The defrost process only starts when both conditions set in parameters 1 and 3 are met. **Not included in model BP-xxWS-B (xx=35, 50).**

<sup>32</sup> The automatic defrost process only stops when one of the conditions set in parameters 2 or 4 are met. **Not included in model BP-xxWS-B (xx=35, 50).**

## 5.2.13.7. Automatic restart.

Following a black out, the parameter enables automatic restart of the operating mode prior to the black out. Example: When parameter 8 (Parameter 2 for model BP-xxWS-B (xx=35, 50)) is 1, when a black out occurs with the heat pump running, see [Paragraph 5.2.4](#), the heat pump automatically restarts when power returns. Vice versa, when parameter 8 (Parameter 2 for model BP-xxWS-B (xx=35, 50)) is 0, the heat pump is in standby when power returns, see [Paragraph 5.2.2](#). The pump must be manually started, see [Paragraph 5.2.4](#).

The pump is set to automatic restart by default.



**Do not change this parameter.**

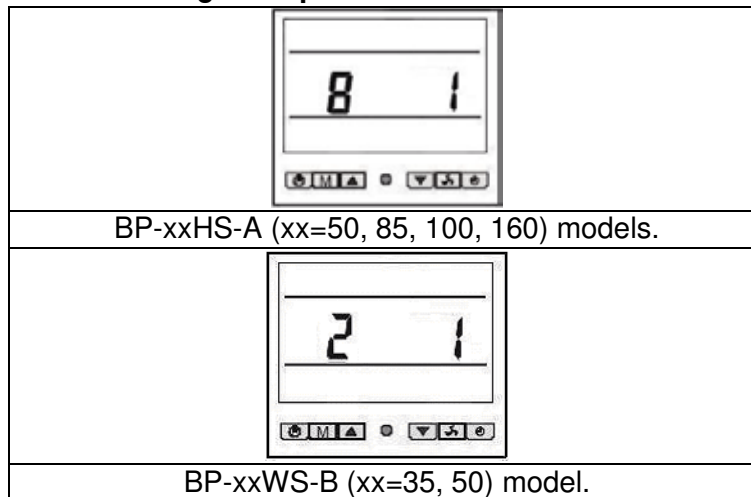

**Figure 33: Parameter 8 settings (2 parameter for model BP-xxWS-B (xx=35, 50)), default settings.**

## 5.2.13.8. Operating mode<sup>33</sup>.

Parameter 9 is used to select the heat pump operating mode. The following operating modes are possible:

- 0. water heating only;
- 1. water heating and cooling;
- 2. water cooling only;
- 3. tank (not applicable in this application).

Default settings include both heating and cooling modes.



**Do not change this parameter.**

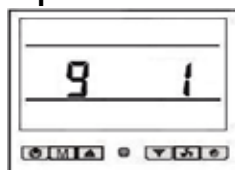

**Figure 34: Parameter 9 settings, default settings.**

## 5.2.13.9. Maximum deviation from set temperature.

Parameter 10 (Parameter 0 for model BP-xxWS-B (xx=35, 50)) is used to select the maximum deviation from the set temperature, see [Paragraph 5.2.6](#). The value can be selected from range 1÷10 [°C].

Default settings are 3 [°C] and this value can be changed based on user need.



Before changing this parameter, please read [Paragraph 1.5](#). Remember that the lower the parameter, the higher the energy consumption. Default

<sup>33</sup> Not included in model BP-xxWS-B (xx=35, 50).

parameter settings were selected to guarantee maximum comfort and minimum energy consumption.

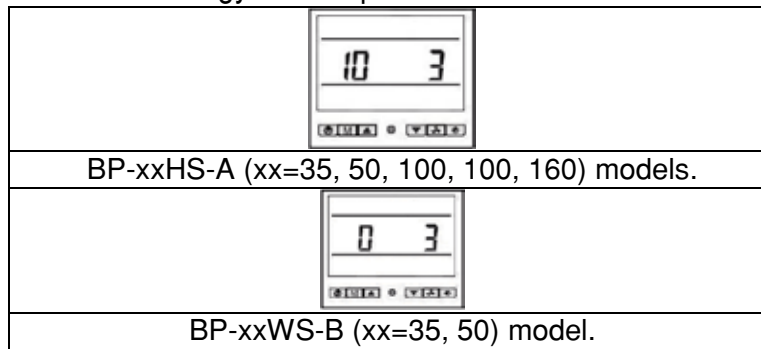

**Figure 35: Parameter 10 settings (0 parameter for model BP-xxWS-B (xx=35, 50)), default settings.**

### 5.2.13.10. Control mode<sup>34</sup>.

Parameter 11 is used to select one of the two control modes<sup>35</sup>:

- 0. heat pump;
- 1. heater.

Heat pump operations are default settings.



**Do not change this parameter.**

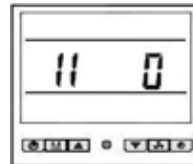

**Figure 36: Parameter 11 settings, default settings.**

### 5.3. Manometer use.

SERIES BP heat pumps are equipped with a manometer that displays refrigerant fluid pressure in the high pressure circuit.

Typical pressure values are the following:

- Heat pump off or in standby, the indicated pressure is between 14÷16 [bar] ([kg/cm<sup>2</sup>]);
- Heat pump running, the indicated pressure is between 21÷35 [bar] ([kg/cm<sup>2</sup>]).

When defrosting, refrigerant fluid pressure is increased to make refrigerant fluid hotter so that it heats the plate heat exchanger during circulation to defrost. Defrosting lasts several minutes.

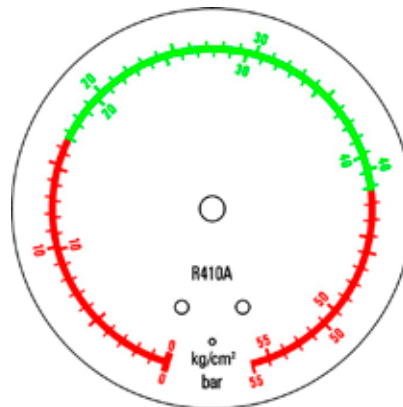

**Figure 1: Manometer.**

## 6. Control and safety devices.

### 6.1. Control devices

#### 6.1.1. Ambient<sup>36</sup> and pool temperature sensors.

SERIES BP control pumps are equipped with sensors that continuously check ambient and pool water temperatures. The sensors are located as illustrated in the following figures.

<sup>34</sup> **Not included in model BP-xxWS-B (xx=35, 50).**

<sup>35</sup> The control board used for SERIES BP heat pumps is designed to be used in various applications. This parameter lets the user select the type of control.

<sup>36</sup> **Not included in model BP-xxWS-B (xx=35, 50).**

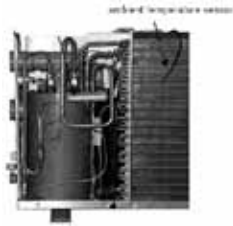

**Figure 37: Ambient temperature sensor.**

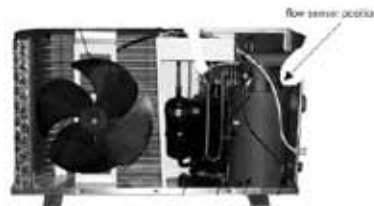

**Figure 38: Pool water temperature sensor.**

Temperature sensors are connected to connector CN4 (ambient temperature and water temperature) as indicated in the wiring diagram, see [Figure 10](#). Sensor operations can be checked by measuring the resistance when temperature changes. Usual values are indicated in [Paragraph 6.3](#).

### 6.1.2. Flow sensor.

SERIES BP control pumps are equipped with a flow sensor that continuously reads water flow. The sensor is located as illustrated in the following figure.



**Figure 39: Flow sensor position.**

## 6.2. Safety devices.

### 6.2.1. Compressor and plate heat exchanger temperature sensors<sup>37</sup>.

SERIES BP heat pumps are equipped with 2 temperature sensors that continuously read compressor and plate heat exchanger temperatures. The sensors are located as illustrated in the following figures.



**Figure 40: Plate heat exchanger temperature sensor.**

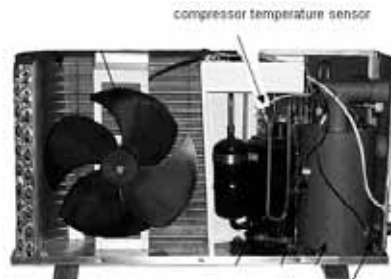

**Figure 41: Compressor temperature sensor.**

Temperature sensors are connected to connector CN4 (compressor temperature and copper sensor) as indicated in the wiring diagram, see [Figure 10](#). Sensor operations can be checked by measuring the resistance when temperature changes. Usual values are indicated in [Paragraph 6.3](#) and [Paragraph 6.4](#).

### 6.2.2. High pressure sensor.

The high pressure sensor stops the compressor when supply pressure, in the refrigerant circuit high pressure section, exceeds the calibration value.



The high pressure sensor signal is not considered during either manual or automatic defrost. For further information see [Paragraph 5.2.10](#) and [Paragraph 5.3](#).

Trigger pressure is 4.2 [bar]. After a high pressure alarm, see [Paragraph 7.5](#), the heat pump must be manually restarted, see [Paragraph 5.2.4](#).

<sup>37</sup> Not necessary in model BP-xxWS-B (xx=35, 50) since there is no plate heat exchanger defrost process.

## 6.2.3. Low pressure sensor.

The low pressure sensor stops the compressor when suction pressure in the high pressure section is under the calibration value.

Trigger pressure is 0.05 [bar]. After a low pressure alarm, the heat pump must be manually restarted, see [Paragraph 5.2.4](#).



Figure 42: High pressure sensor.



Figure 43: Low pressure sensor.

## 6.3. Pool, ambient and plate heat exchanger temperature sensor resistance values.

water temperature sensor, ambient temperature sensor, coil sensor

temperature (°C)	resistance (K)	temperature (°C)	resistance (K)	temperature (°C)	resistance (K)
-20	37.4111	9	9.5794	38	3.0815
-19	35.5384	10	9.1801	39	2.9733
-18	33.7705	11	8.7999	40	2.8694
-17	32.1009	12	8.4377	41	2.7697
-16	30.5237	13	8.0925	42	2.6740
-15	29.0333	14	7.7635	43	2.5821
-14	27.6246	15	7.4498	44	2.4939
-13	26.2927	16	7.1506	45	2.4091
-12	25.0330	17	6.8652	46	2.3276
-11	23.8412	18	6.5928	47	2.2493
-10	22.7133	19	6.3328	48	2.1740
-9	21.6456	20	6.0846	49	2.1017
-8	20.6345	21	5.8475	50	2.0320
-7	19.6768	22	5.6210	51	1.9651
-6	18.7693	23	5.4046	52	1.9007
-5	17.9092	24	5.1978	53	1.8387
-4	17.0937	25	5.0000	54	1.7790
-3	16.3203	26	4.8109	55	1.7216
-2	15.5866	27	4.6300	56	1.6663
-1	14.8903	28	4.4569	57	1.6131
0	14.2293	29	4.2912	58	1.5618
1	13.6017	30	4.1327	59	1.5123
2	13.0055	31	3.9808	60	1.4647
3	12.4391	32	3.8354	61	1.4188
4	11.9008	33	3.6961	62	1.3746
5	11.3890	34	3.5626	63	1.3319
6	10.9023	35	3.4346	64	1.2908
7	10.4393	36	3.3120	65	1.2511
8	9.9987	37	3.1943	66	1.2128

Table 4: Pool, ambient and plate heat exchanger temperature sensor resistance values.

## 6.4. Compressor temperature sensor resistance values

compressor exhaust temperature sensor

temperature (°C)	resistance (K)	temperature (°C)	resistance (K)	temperature (°C)	resistance (K)	temperature (°C)	resistance (K)	temperature (°C)	resistance (K)	temperature (°C)	resistance (K)
-30	866.96	-4	199.98	22	57.104	48	19.368	74	7.5586	100	3.3120
-29	815.70	-3	189.86	23	54.620	49	18.635	75	7.3077	101	3.2150
-28	767.71	-2	180.34	24	52.253	50	17.932	76	7.0667	102	3.1214
-27	722.87	-1	171.33	25	50.000	51	17.260	77	6.8345	103	3.0310
-26	680.87	0	162.81	26	47.857	52	16.616	78	6.6109	104	2.9435
-25	641.59	1	154.78	27	45.817	53	16.001	79	6.3960	105	2.8589
-24	604.82	2	147.19	28	43.877	54	15.410	80	6.1890	106	2.7772
-23	570.34	3	140.00	29	42.027	55	14.844	81	5.9894	107	2.6982
-22	538.03	4	133.21	30	40.265	56	14.302	82	5.7976	108	2.6218
-21	507.74	5	126.79	31	38.585	57	13.782	83	5.6126	109	2.5479
-20	479.34	6	120.72	32	36.987	58	13.284	84	5.4346	110	2.4764
-19	452.68	7	114.96	33	35.462	59	12.807	85	5.2629	111	2.4072
-18	427.67	8	109.51	34	34.007	60	12.348	86	5.0974	112	2.3403
-17	404.17	9	104.34	35	32.619	61	11.909	87	4.9379	113	2.2755
-16	382.11	10	99.456	36	31.297	62	11.487	88	4.7842	114	2.2128
-15	361.35	11	94.826	37	30.034	63	11.083	89	4.6359	115	2.1522
-14	341.86	12	90.426	38	28.827	64	10.694	90	4.4931	116	2.0934
-13	323.53	13	86.262	39	27.677	65	10.321	91	4.3552	117	2.0365
-12	306.29	14	82.312	40	26.578	66	9.9628	92	4.2222	118	1.9814
-11	290.06	15	78.561	41	25.528	67	9.6187	93	4.0939	119	1.9280
-10	274.78	16	75.001	42	24.524	68	9.2882	94	3.9700	120	1.8764
-9	260.40	17	71.625	43	23.566	69	8.9706	95	3.8506	121	1.8263
-8	246.85	18	68.416	44	22.648	70	8.6655	96	3.7351	122	1.7778
-7	234.08	19	65.368	45	21.773	71	8.3723	97	3.6238	123	1.7308
-6	222.02	20	62.474	46	20.935	72	8.0903	98	3.5162	124	1.6852
-5	210.69	21	59.719	47	20.134	73	7.8193	99	3.4123	125	1.6411

Table 5: Compressor temperature sensor resistance values.



## 7. Routine, scheduled and extraordinary maintenance.



Periodic controls are required to keep SERIES BP heat pumps in good working order and to guarantee the foreseen performance and safety levels. Some controls can be performed by the user while specialised technicians are required for others.



**During normal operations, the heat pump plate heat exchanger produces condensation. The amount of condensation produced varies according to ambient conditions. The higher the air humidity, the higher the amount of condensation produced. The lower heat pump panel acts as a condensation collection tray. Keep the drain hole clean.**

### 7.1. User controls.

SERIES BP heat pump users must periodically make sure that:

- Dirt is not accumulated near the heat pump (leaves, paper, etc.). Performing this control weekly is recommended. Use caution when nearing the plate heat exchanger blade since rather sharp.
- There are no leaks in the hydraulic circuit. Conduct this control monthly.
- Electrical mains wires and connections are integral, Performing this control monthly is recommended.
- The correct chemical balance in the pool water is guaranteed in order to guarantee hygienic accessibility conditions and long heat pump life. Conducting this control daily with specific retail kits is recommended.
- The pressure values indicated on the manometer are correct. See [Paragraph 5.3](#).
- Make sure the condensation drain hole is open.

### 7.2. Specialised technician controls.

The following controls must be conducted by a specialised technician at least once a year to guarantee safe and efficient SERIES BP heat pump operations:

- Electrical mains wire and connection integrity.
- Hydraulic system integrity.
- Inspect and clean the plate heat exchanger coil.
- Check correct heat pump operations, start, see [Paragraph 5.2.4](#).
- Check usual pressure values indicated by the manometer, see [Paragraph 5.3](#).
- Make sure there are no oil leaks from the compressor.

### 7.3. Winter protection.

The following instructions must be observed to protect SERIES BP heat pumps for the winter:

- Disconnect the electrical mains using the protection device and/or contact switch, see [Paragraph 5.2.3](#).
- Drain the heat pump hydraulic system using the cut-off valve, see [Paragraph 4.5](#).
- Protect the plate heat exchanger and fan from dirt accumulation. Do not wrap the heat pump with plastic or other material that can hold heat and/or humidity inside the device.

### 7.4. Spring commissioning.

The following instructions must be observed for SERIES BP heat pump spring commissioning.

- Remove any protections used for winter protection, see [Paragraph 7.3](#).
- Fill the heat pump hydraulic system using the cut-off valve, see [Paragraph 4.5](#).
- Check the water chemical composition, see [Paragraph 7.1](#), act accordingly if necessary.
- Restore the electrical mains using the protection device and/or contact switch, see [Paragraph 4.6](#).

### 7.5. Troubleshooting.

The following table can be used to solve main heat pump problems. When a message error is displayed, the following is required to restore operations:

# ENGLISH

- turn off the heat pump, see [Paragraph 5.2.3](#);
- turn on the heat pump, see [Paragraph 5.2.1](#);
- start the heat pump, see [Paragraph 5.2.4](#).

Problem	Possible cause	1 <sup>st</sup> solution	2 <sup>nd</sup> solution
The heat pump does not turn on, see <a href="#">Paragraph 5.2.1</a> .	The instructions in <a href="#">Paragraph 5.2.1</a> were not followed.	Follow the instructions in <a href="#">Paragraph 5.2.1</a>	
	The mains connection line protection device fuse is burned out or the contact switch triggered, see <a href="#">Paragraph 4.6</a> .	Reset the switch and/or replace the fuse.	
The heat pump does not start, see <a href="#">Paragraph 5.2.6</a> .	The 3 minutes required for pump start have not elapsed. See <a href="#">Paragraph 5.2.4</a> .	Wait until the 3 minutes required for pump start have elapsed. See <a href="#">Paragraph 5.2.4</a> .	
	Pool temperature is greater than or equal to set temperature. See <a href="#">Paragraph 5.2.6</a> .	The pump will start when the pool temperature is lower than the set temperature. See <a href="#">Paragraph 5.2.6</a> .	
	The pump operating mode is not the required mode. See <a href="#">Paragraph 5.2.5</a> .	Set the required operating mode. See <a href="#">Paragraph 5.2.5</a> .	
The heat pump is running but the water is not heating.	Make sure air exits the front part of the heat pump. See <a href="#">Figure 1</a> .		
	The heat pump was just installed.	24÷48 hours may be required to reach the set temperature. See <a href="#">Paragraph 1.5</a> .	
	Pool water has significantly cooled since the last heat pump use.	24÷36 hours may be required to reach the set temperature. See <a href="#">Paragraph 1.5</a> .	
There is frost on the plate heat exchanger.	Too low ambient temperature and/or a significant amount of humidity in the air.	Start manual defrost. See <a href="#">Paragraph 5.2.10</a> .	
	Pressure refrigerant drop down.	Verify leakage.	Replace refrigerant.

# ENGLISH

Problem	Possible cause	1 <sup>st</sup> solution	2 <sup>nd</sup> solution
Water leaks from the heat pump.	Probable accumulation of condensation. See <a href="#">Paragraph 4.3</a> .	Put the heat pump in standby, see <a href="#">Paragraph 5.2.2</a> , if the leak stops, this is normal condensation.	
	Possible water leak from the water exchanger or from hydraulic unit connection devices. See <a href="#">Figure 1</a> and/or <a href="#">Figure 5</a> .	Tighten the fastening nut, for an example, see <a href="#">Figure 5</a> .	
Error message <b>EE b</b> is displayed.	Insufficient water flow	Increase water flow in the hydraulic circuit that supplies the heat pump. After 2 minutes restart.	
	Flow sensor incorrectly connected or defective.	Check connections and replace if necessary.	Replace the control board.
Error message <b>EE c</b> is displayed.	Ambient temperature under -15 [°C]. See <a href="#">Paragraph 5.2.7</a> .	Wait until ambient temperature rises to start the heat pump.	
	Ambient temperature lower than minimum working temperature. See <a href="#">Paragraph 5.2.7</a> .	Set minimum working temperature again, see <a href="#">Paragraph 5.2.7</a> , or wait until ambient temperature rises to start the heat pump.	
Error message <b>EE d</b> is displayed.	Functional parameter changes. Parameter 9 is not set to 0.	Set correct parameter values to 1. See <a href="#">Paragraph 5.2.13.7</a> .	Replace the control board. See <a href="#">Figure 9</a> .
The heat pump does not work <sup>38</sup> and error message <b>EE 1</b> is displayed.	Pool temperature sensor incorrectly connected or defective.	Check the sensor resistance value, see <a href="#">Paragraph 6.1.1</a> , and replace if necessary.	Replace the control board. See <a href="#">Figure 9</a> .
The heat pump does not work <sup>39</sup> and error message <b>EE 2</b> is displayed.	Ambient temperature sensor incorrectly connected or defective.	Check the sensor resistance value, see <a href="#">Paragraph 6.1.1</a> , and replace if necessary.	Replace the control board. See <a href="#">Figure 9</a> .
The heat pump is running work <sup>40</sup> and error message <b>EE 3</b> is displayed.	Compressor temperature sensor incorrectly connected or defective.	Check the sensor resistance value, see <a href="#">Paragraph 6.2.1</a> , and replace if necessary.	Replace the control board. See <a href="#">Figure 9</a> .
The heat pump is running <sup>41</sup> and error message <b>EE 4</b> is displayed.	Automatic defrost did not run correctly.	Increase water flow at pump inlet.	
	Plate heat exchanger temperature sensor incorrectly connected or defective.	Check the sensor resistance value, see <a href="#">Paragraph 6.2.1</a> , and replace if necessary.	Replace the control board. See <a href="#">Figure 9</a> .
Error message <b>EE 5</b> is displayed <sup>42</sup> .		Replace the control board. See <a href="#">Figure 9</a> .	

<sup>38</sup> Compressor and fan off.

<sup>39</sup> Compressor and fan off.

<sup>40</sup> Compressor and fan on.

<sup>41</sup> Compressor and fan on.

<sup>42</sup> This error message is not used and should not be displayed.

# ENGLISH

Problem	Possible cause	1 <sup>st</sup> solution	2 <sup>nd</sup> solution
The heat pump does not work <sup>43</sup> and error message <b>EE 6</b> is displayed.	Compressor temperature too high.	Wait until compressor temperature drops.	
	Refrigerant circuit leak <sup>44</sup> .	Check for leaks with a leak detector and replace defective refrigerant circuit parts.	
	Capillary circuit clogged	Replace the capillary circuit.	
The heat pump does not work <sup>45</sup> and error message <b>EE 7</b> is displayed.	Current dispersion	Replace the defective component: Compressor, fan, four way valve, electronic board.	
The heat pump does not work and error message <b>EE 8</b> is displayed.	Control board wiring defective.	Check wiring.	Replace the control board.
Error message <b>EE 9</b> is displayed.	High or low pressure sensor incorrectly connected or defective.	Check connections and replace if necessary.	
	Pool temperature too high.	Wait until pool temperature drops.	
	Ambient temperature too high.	Wait until ambient temperature drops.	
	Capillary circuit clogged	Replace the capillary circuit.	
	Manual defrost started without frost on plate heat exchanger	Turn off, see <a href="#">Paragraph 5.2.3</a> , turn on, see <a href="#">Paragraph 5.2.1</a> , and start the pump, see <a href="#">Paragraph 5.2.4</a>	

<sup>43</sup> Compressor and fan off.

<sup>44</sup> Manometer in red zone.

<sup>45</sup> Compressor and fan off.

## 8. Spare parts.

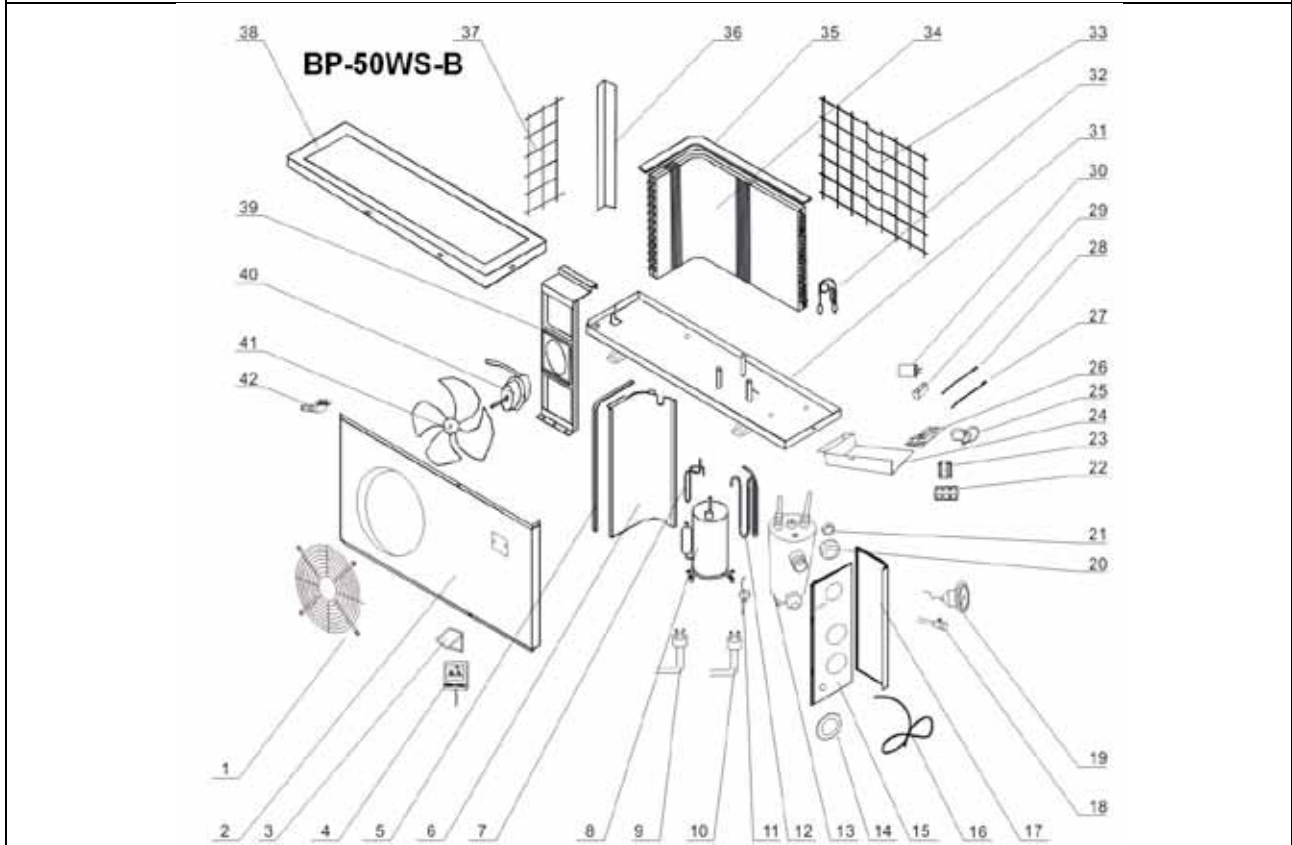
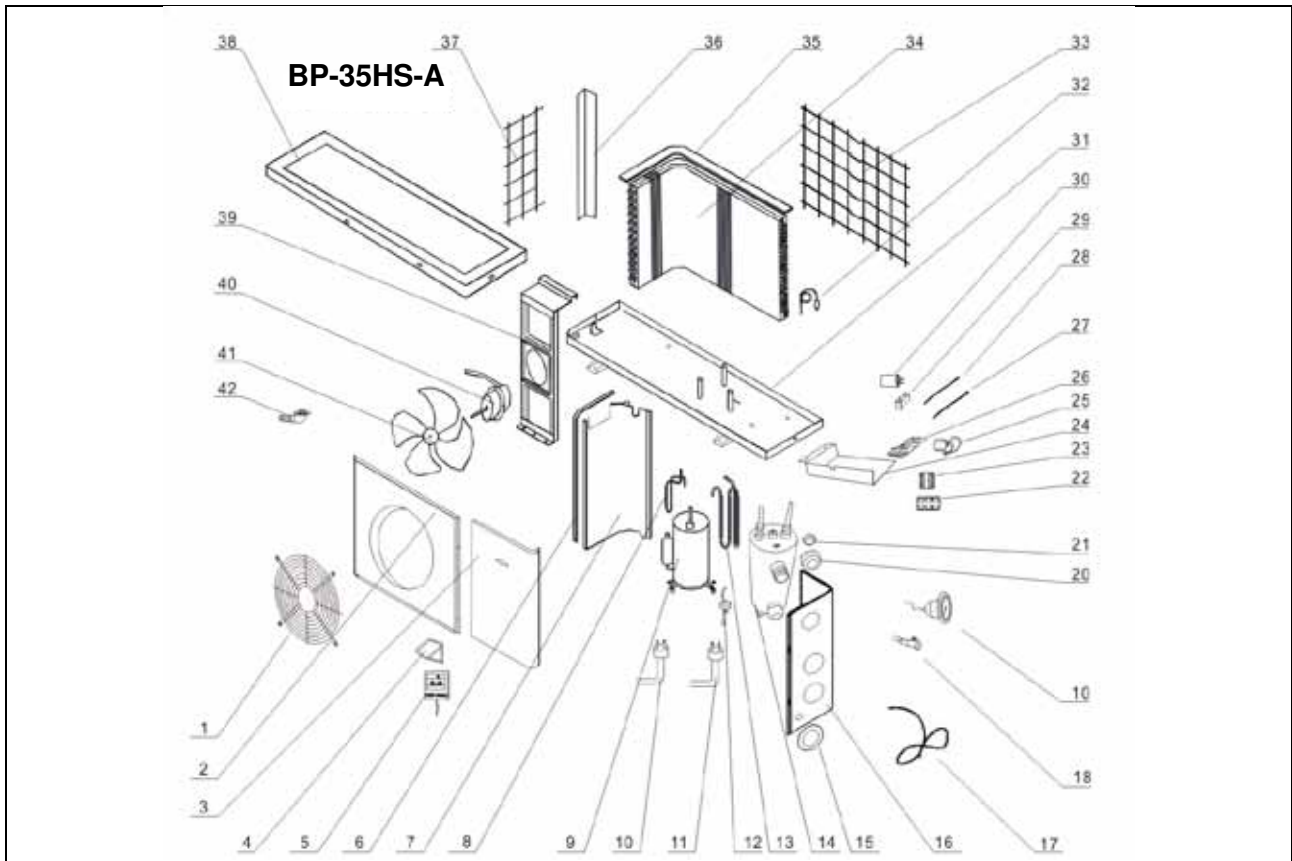

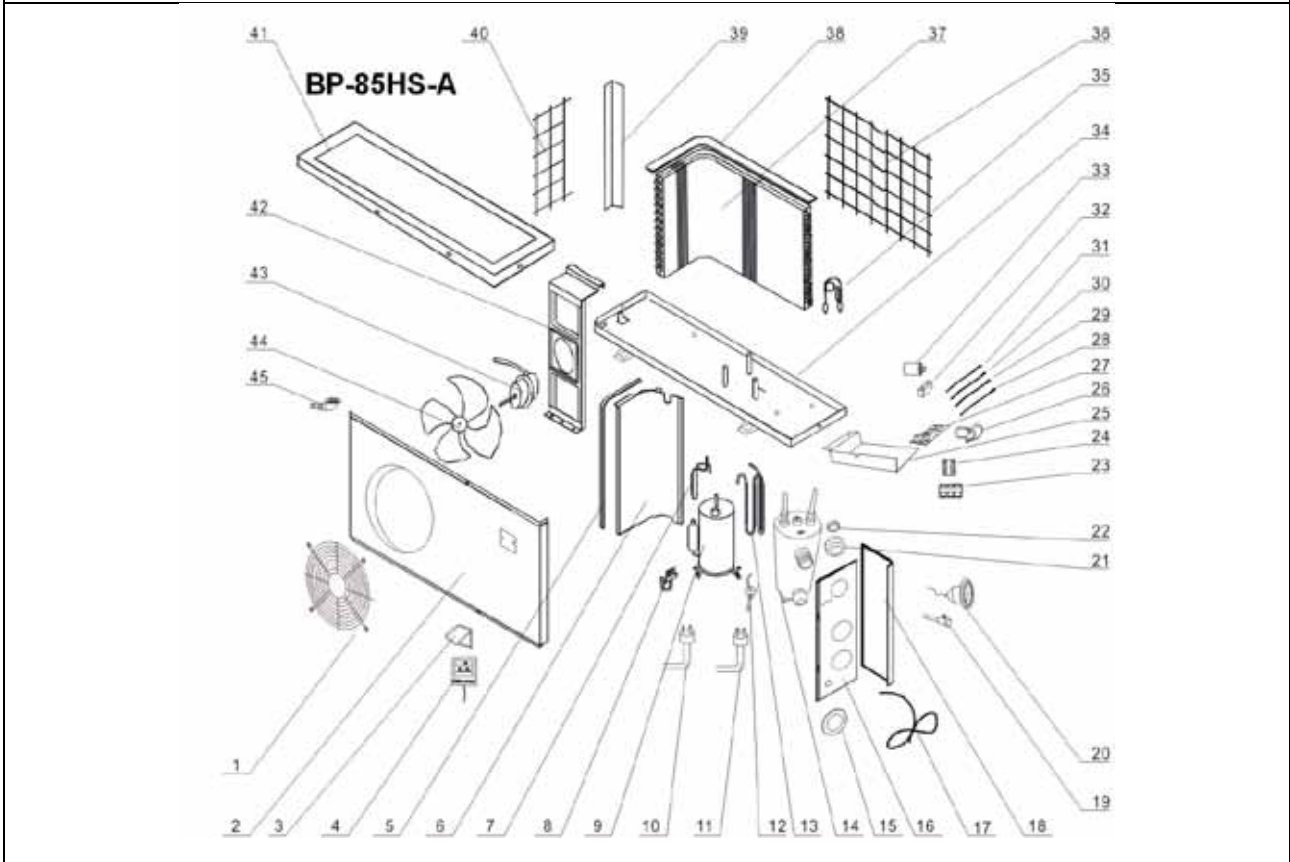
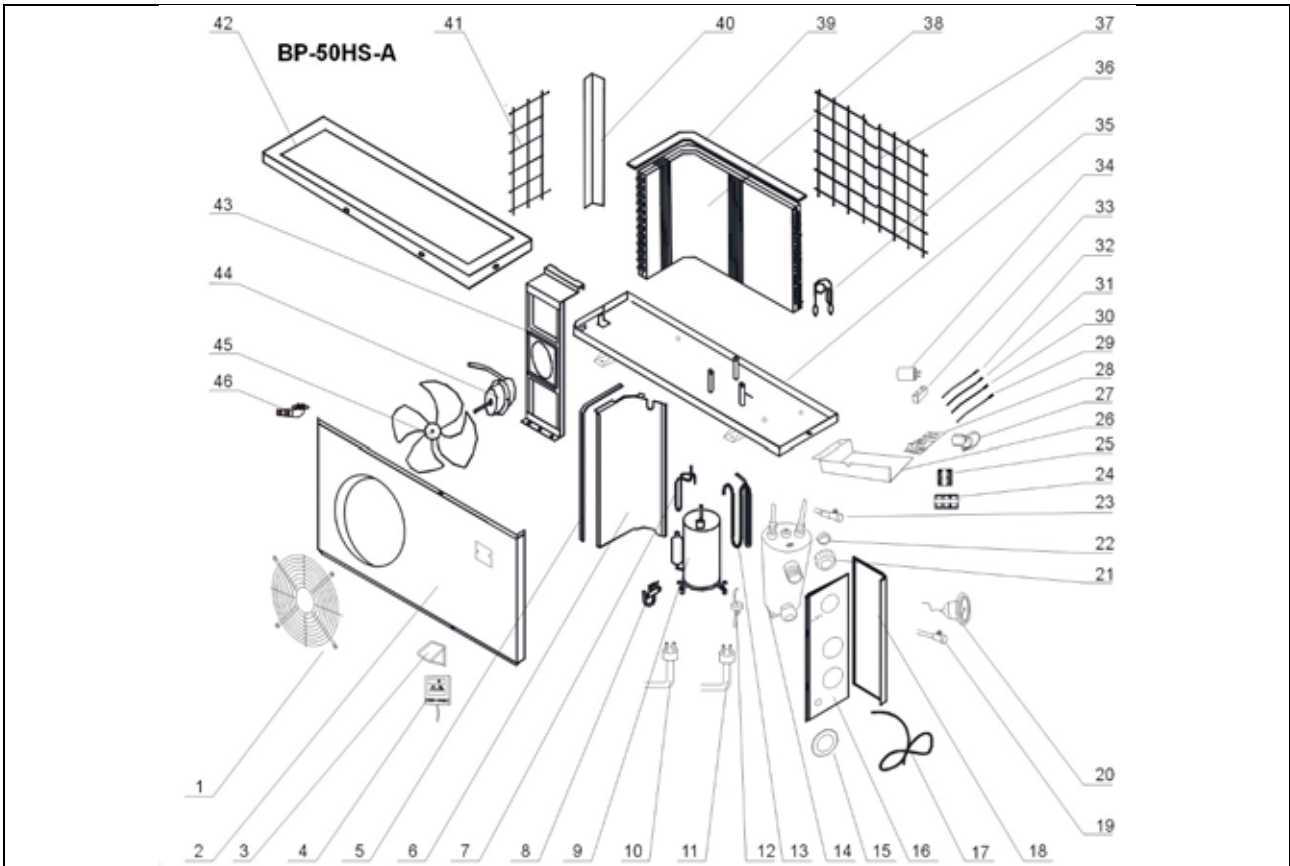

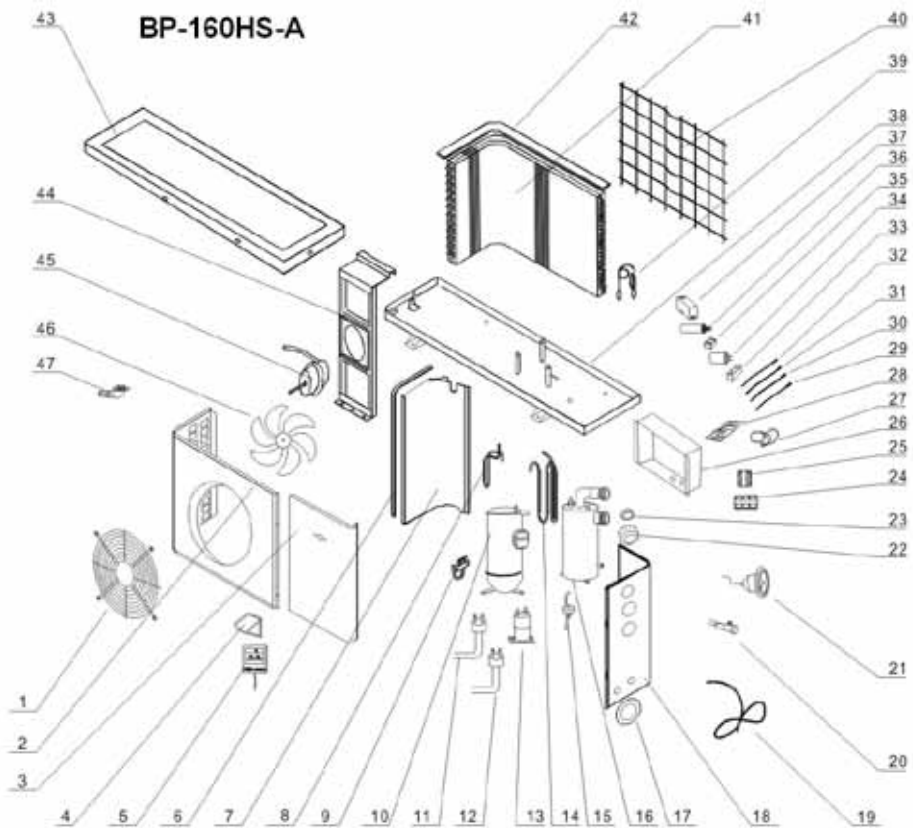
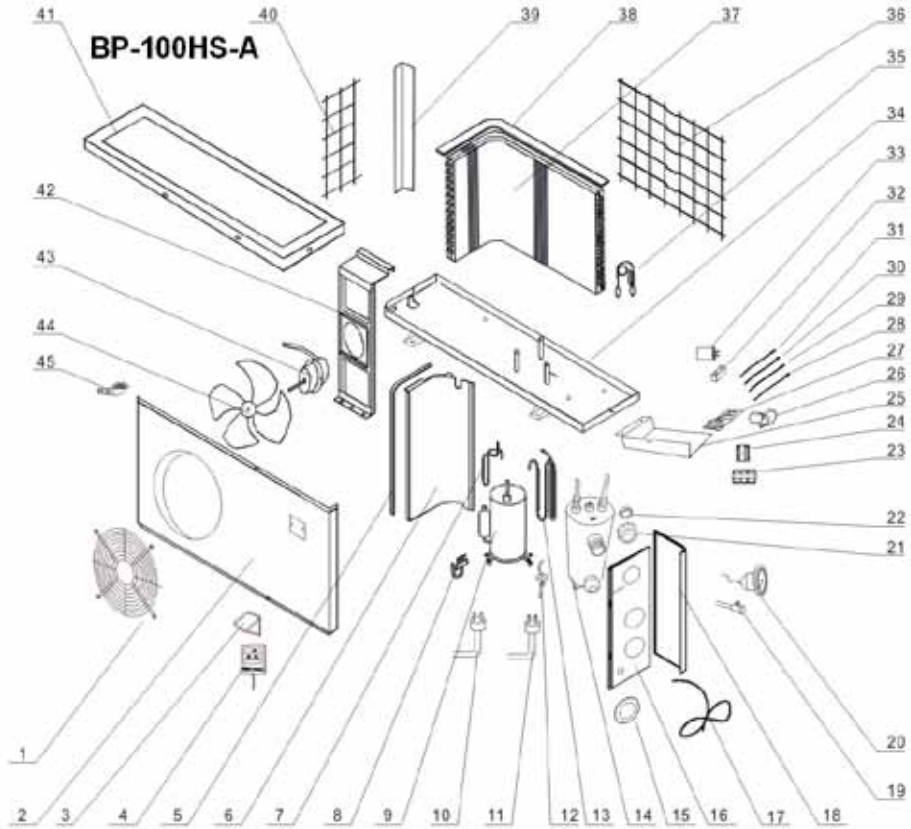

# ENGLISH

#	BP-3BWS-B	BP-3BHS-A	BP-50WS-B	BP-50HS-A	BP-85HS-A	BP-100HS-A	BP-160HS-A	
1	X							XW35HSI001A
			X	X	X			XW50HSI001A
						X		XW100HSI001A
							X	XW160HSI001A
2	X	X						XW35HSI002A
3	X	X						XW35HSI002B
2			X	X	X			XW50HSI002A
2						X		XW100HSI002A
2							X	XW160HSI002A
3							X	XW160HSI002B
3				X				XW50HSI003A
3			X	X	X	X		XW50HSI003B
4	X	X					X	XW50WSI004A
5	X		X					XW50HSI004A
4				X	X	X		-
5		X					X	XW50HSI005A
6	X	X						XW100HSI005A
5			X	X	X			XW160HSI005A
7	X	X					X	XW35HSI006A
6			X	X	X			XW50HSI006A
6						X		XW100HSI006A
7							X	XW160HSI006A
8	X							XW35WSI007A
8		X						-
7			X	X				XW50HSI007A
7					X			XW85HSI007A
7						X		XW100HSI007A
8							X	XW160HSI007A
9	X							XW35HSI009A
10		X						XW50HSI009A
8			X					XW50HSI009A
9				X				XW85HSI009A
9					X		X	XW100HSI009A
10							X	XW160HSI009A
9			X					XW50HSI010A
10	X			X	X	X		XW50HSI010A
11		X					X	XW50HSI011A
10			X					XW50HSI011A
11	X			X	X	X		XW50HSI011A
12		X					X	XW50HSI012A
12				X				XW50HSI012A
12	X			X	X	X		XW50HSI012A
11			X					XW50HSI012B
13		X						XW50HSI012B
15							X	XW50HSI012B
13	X							XW35WSI013A
14		X						-
12			X					XW50HSI013A
13				X				XW50HSI013A
13					X			XW85HSI013A
13						X		XW100HSI013A
14							X	XW160HSI013A
14	X							XW35HSI014A
15		X						XW50HSI014A
14				X				XW50HSI014A
13			X					XW50HSI014B
14				X				XW50HSI014B
14					X			XW85HSI014A
14						X		XW100HSI014A
16							X	XW160HSI014A
15	X							-
16		X						XW50HSI015B
14			X					XW50HSI015B
15	X			X	X	X		XW50HSI015B
16		X						XW50HSI015B
17							X	XW50HSI015B
16	X							XW35HSI016A
17		X						XW35HSI016A
16			X	X	X			XW50HSI016A
16						X		XW100HSI016A
18							X	XW160HSI016A

#	BP-3BWS-B	BP-3BHS-A	BP-50WS-B	BP-50HS-A	BP-85HS-A	BP-100HS-A	BP-160HS-A	
17			X					XW50HSI018A
18				X	X			XW50HSI018A
18						X		XW100HSI018A
17	X							XW35HSI017A
18		X						XW35HSI017A
15			X					XW50HSI017A
17				X	X			XW50HSI017A
17						X		XW100HSI017A
19							X	XW160HSI017A
9		X						XW50HSI008A
8				X				XW85HSI008A
8					X			XW100HSI008A
8						X		XW100HSI008A
9							X	XW160HSI008A
18	X		X					XW50HSI019A
19		X		X	X	X		XW50HSI019A
20							X	XW50HSI019A
19	X		X					XW50HSI020A
20		X		X	X	X		XW50HSI020A
21							X	XW50HSI020A
20	X							-
21		X						-
21	X							-
22		X						-
20			X					-
21				X	X	X		-
22							X	-
21	X		X					XW50HSI022A
22		X		X	X	X		XW50HSI022A
23							X	XW50HSI022A
23				X				XW50HSI023A
22	X		X					XW50HSI024A
23		X			X	X		XW50HSI024A
24				X			X	XW50HSI024A
23	X		X					XW50HSI025A
24		X			X	X		XW50HSI025A
25				X			X	XW50HSI025A
24	X							XW35HSI026A
25		X						XW35HSI026A
26				X				XW50HSI026A
25					X			XW50HSI026A
24			X					XW100HSI026A
25						X		XW100HSI026A
26							X	XW160HSI026A
27				X			X	XW50HSI026A
26		X			X	X		XW50HSI026A
25	X		X					XW50HSI026A
26	X		X					XW50WSI028A
28				X				XW50HSI028A
28				X				XW50HSI028B
28				X				XW50HSI028C
28				X			X	XW50HSI028D
27		X			X	X		XW50HSI028D
28		X			X	X		XW50HSI029A
28		X			X	X		XW50HSI029A
29				X			X	XW50HSI029A
27	X							XW50HSI030A
29		X			X	X		XW50HSI030A
27			X					XW50HSI030A
30				X			X	XW50HSI030A
28								XW50HSI030A
30		X						XW50HSI031A
30					X	X		XW50HSI031A
31				X			X	XW50HSI031A
28	X							XW50HSI032A
31		X						XW50HSI032A
32				X				XW50HSI032A
28			X					XW50HSI032A
31					X	X		XW50HSI032A
32							X	XW50HSI032A



# ENGLISH

#	BP-3BWS-B	BP-3BHS-A	BP-50WS-B	BP-50HS-A	BP-85HS-A	BP-100HS-A	BP-160HS-A		
29	X							XW50HSI033A	
32		X							
29			X						
33				X					
32					X			XW85HSI033A	
32						X		XW100HSI033A	
33							X	XW160HSI033A	
30	X							XW50HSI034A	
33		X							
34				X					
30			X						
33					X				XW85HSI034A
33						X	X		XW100HSI034A
34							X	XW160HSI034A	
31	X							XW35HSI035A	
34		X						XW50HSI035A	
35				X					
31			X						
34					X				
34						X		XW100HSI035A	
38							X	XW160HSI035A	
32	X							XW35WSI036A	
35		X						-	
32			X					XW50WSI036A	
36				X				XW50HSI036A	
35					X			XW85HSI036A	
35						X		XW100HSI036A	
39							X	XW160HSI036A	
33	X							XW35HSI037A	
36		X						XW50HSI037A	
37				X					
33			X						
36					X				
36						X		XW100HSI037A	
40							X	XW160HSI037A	
34	X							XW35HSI038A	
37		X						XW50HSI038A	
38				X					
34			X						
37					X				
37						X			
41							X		XW160HSI038A
35			X					XW50WSI039A	
38		X						XW50HSI039A	
35	X								
39				X					
38					X				
38						X		XW100HSI039A	
42							X	XW160HSI039A	
36	X							XW35HSI040A	
39		X						XW50HSI040A	
40				X					
38			X						
39					X				
39						X			
37	X							XW35HSI041A	
40		X						XW50HSI041A	
41				X					
37			X						
41					X				
40						X		XW100HSI041A	
41		X						XW35HSI042A	
38	X								
42				X					
38			X						
41					X				
43						X			XW100HSI042A
43							X	XW160HSI042A	
42	X	X						XW35HSI043A	
43				X				XW50HSI043A	
39			X						
42					X				
42						X			XW100HSI043A
44							X	XW160HSI043A	

#	BP-3BWS-B	BP-3BHS-A	BP-50WS-B	BP-50HS-A	BP-85HS-A	BP-100HS-A	BP-160HS-A	
43		X						XW35HSI044A
40	X							
44					X			XW50HSI044A
40			X					
43					X			XW85HSI044A
43						X		XW100HSI044A
45							X	XW160HSI044A
41	X							XW35HSI045A
44		X						
45					X			XW50HSI045A
41			X					
44					X			
44						X		
46							X	XW160HSI045A
46				X				XW50HSI046A
42	X		X					
45		X			X	X		
20							X	XW160HSI046A
13							X	XW160HSI048A
35							X	XW160HSI049A
36							X	XW160HSI050A
37							X	XW160HSI051A

## 8.1. Special notes on part replacement.

### 8.1.1. Manometer replacement.

Before replacing the manometer, close the valve upstream from the manometer.



Valve to be closed



Figure 44: Manometer replacement.

### 8.1.2. Pressure sensor replacement.

Use blow torch for pressure sensor replacement.



Figure 45: High pressure sensor.



Figure 46: Low pressure sensor.

### 8.1.3. Filter and capillary replacement.

The filter and capillary must be replaced using a blow torch. The capillary only needs replacement if, during normal machine operations, the temperature difference, between capillary circuit input and output is negligible.



Figure 47: Filter.

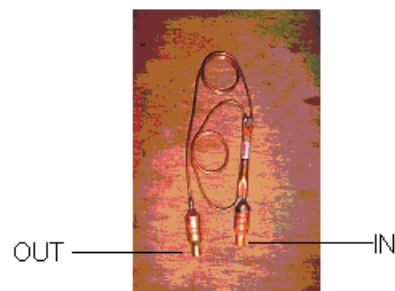

Figure 48: Capillary.

### 8.1.4. Frost on radiator.

Check refrigerant fluid pressure. If necessary charge the circuit. See [Paragraph 5.3](#).



 **speedheat** Waterpower 3600

Art.Nr.: 049203 / BP-35HS-A1

 **speedheat** Waterpower 5000

Art.Nr.: 049201 / BP-50HS-A1

 **speedheat** Waterpower 8500

Art.Nr.: 049206 / BP-85HS-A1

